

# Laser Cutting Machine Manual

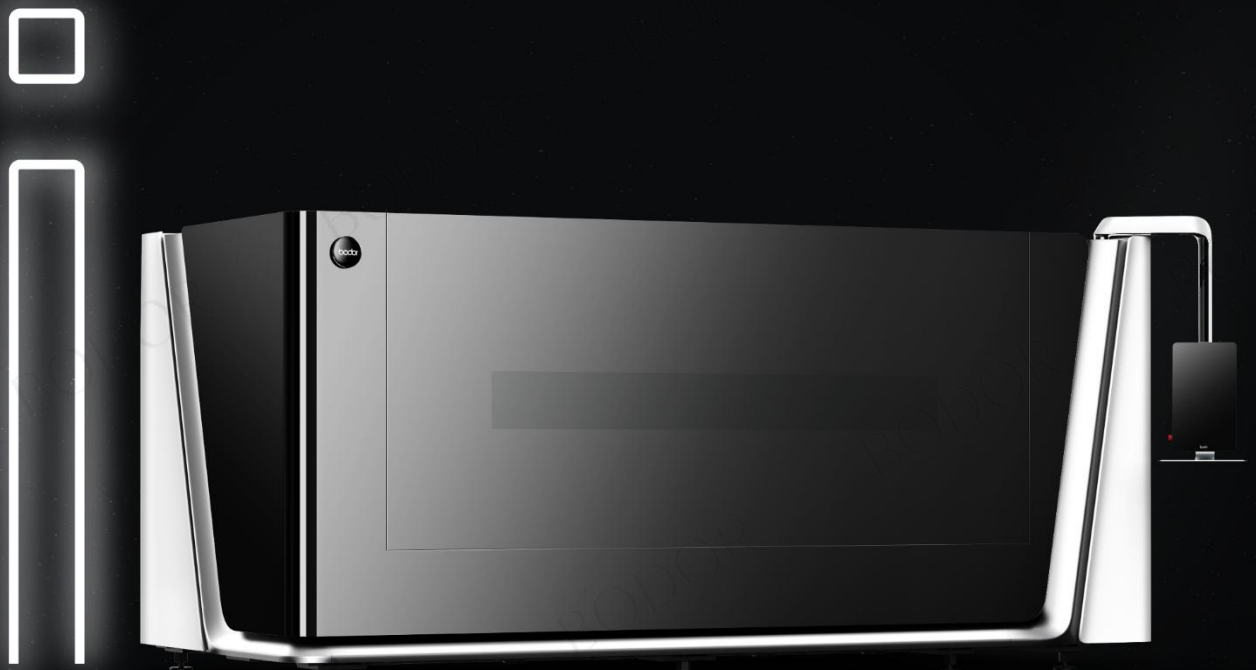

i Series Product analysis & Instructions for quick learning

## Overview

To begin with, it is a great honor to cooperate with you as a partner. What's next is a magical journey that laser processing technology brings to us. Let's enjoy it!

We believe this is just a start, and we genuinely wish that we can "Change Human Life with Laser Technology" together.

If this is your first time knowing the mysterious power of laser, make sure to read the instructions before installation.

Jinan Bodor CNC Machine Co., Ltd.

[www.bodor.com](http://www.bodor.com)/+86-531-88690051



## Statements

Instruction is essential to the safe use and easy maintenance of the equipment. This manual arrives with the machine to customers albeit the machine is resold. The manual should be changed in time once it is lost, broken, or illegible.

The continuous safe and effective use of the machine should be ensured and no modifications to the machine without the approval of the manufacturer are allowed. Jinan Bodor CNC Machine Co., Ltd. (hereinafter referred to as Bodor) is not responsible for any faults resulting from the modifications above, and solutions to these faults will not be included in the supporting services by the manufacturer or the product warranty. Please inform Bodor in writing if there is any problem with the machine. We will evaluate the problem and provide the necessary information when the machine service is valid. Problems caused by improper use or non-compliance with Bodor instructions are not covered by the warranty.

Bodor has checked the contents of the instructions to ensure that they are consistent with the products described. The information contained in the manual will be reviewed regularly and any necessary modifications will be included in the next edition. It is appreciated that you have any suggestions for improvement.

Bodor reserves the right to improve and upgrade the products described in the manual. Therefore, the technical parameters of the machine and the technical documents including the manual may be adjusted accordingly without notice.



Bodor reserves all rights to the instructions. No part of the instructions may be reproduced in any form without Bodor's written permission. Exceptions must be explicitly approved by Bodor. Those who do not comply with the regulations are obliged to compensate for the damage and take possible legal consequences.

Please do not hesitate to consult us if you have any questions or better advice by visiting our website: [www.bodor.com](http://www.bodor.com), or calling the 24-hour telephone: +86-531-88690051.

Other documents provided and used together with the manual are shown in Table 1-1.

Table 1-1 Reference documents list

No.	Document name	No.	Document name
1	Operating system manual	7	Electrical schematic diagram
2	On site operation instruction	8	Cutting gas path schematic diagram
3	Guide for use of auto focus laser cutting head	9	Schematic diagram of water pipeline
4	Site layout	10	Pneumatic schematic diagram
5	Foundation map	11	Lubrication schematic
6	Hoisting diagram	12	

**Statement: If the user permits our installation and debugging, it means that the user agrees with the shipping list without any objections.**



# Catalog

Safety Notes .....	7
I. Overview .....	10
1.1 Scope of application .....	10
1.2 Signal words .....	10
1.3 Intended readers .....	11
1.4 Terms .....	11
1.5 Abbreviations .....	11
1.6 Unit of measurement .....	12
1.7 Explanation of illustrations .....	12
1.8 Conformity of machine .....	12
II. Safe operation of equipment .....	14
2.1 Basic safety rules .....	14
2.2 Machine nameplate .....	16
2.3 Intended use and reasonably foreseeable misuse .....	17
2.4 Operation positions .....	17
2.5 Operation environment .....	18
2.6 Energy requirements .....	21
2.7 Residual risks and safety labels .....	23
2.8 Safeguards .....	28
2.9 Safety instructions for machine lifecycle .....	30
2.10 Laser safety .....	34
Guide of Complete Machine Assembly and Disassembly .....	38
I.Preparedness Plan .....	40
1.1 Installation Conditions .....	41
1.2 Power Supply .....	42
1.3 Running Materials .....	45



II. Transport and Handling .....	
2.1 Requirements for Transport .....	46
2.2 Requirements for Handling .....	46
2.3 Handling Tools .....	47
2.4 Hoisting Position and Forklifting Point of the Lathe Bed .....	48
2.5 Storage Conditions, Period and Notes .....	48
Installation and Debugging Guide .....	49
I. Brief Introduction to the Structure .....	49
1.1 Composition of Complete Machine .....	49
1.2 Introduction to Important Components .....	49
1.3 Introduction to Each Functional System .....	52
II. Equipment Installation and Connection .....	55
2.1 Inspection and Acceptance after the Arrival of the Equipment .....	55
2.2 Specification and Requirements for Packaging Removal .....	56
2.3 Equipment mechanical installation process .....	56
2.4 Circuit Connection .....	56
2.5 Connection to Gas Circuit .....	58
2.6 Connection to Waterway .....	59
III. Equipment Startup and Debugging .....	60
3.1 Start-up Process .....	60
3.2 Inspection of Waterways .....	60
3.3 Inspection of Gas Circuit .....	61
3.4 Motion unit test .....	61
3.5 Test of Light Emission .....	61
3.6 Turning off the Machine Tool .....	62
3.7 Summary .....	62
Equipment Operating Instruction .....	64
I. Basic Knowledge of Laser Machining .....	64



1.1 Laser Machining Principle ..... 64

1.2 Main Methods of Laser Machining ..... 64

1.3 Focal Position ..... 65

1.4 Nozzle ..... 66

1.5 Dimming ( Laser coaxial) ..... 67

1.6 Factors Affecting the Cutting Technology ..... 69

II. Application of External Functions of the Equipment ..... 80

2.1 USB Interface ..... 80

2.2 Return to Zero ..... 80

2.3 Draught Fan Startup ..... 80

2.4 Automatic Focusing ..... 80

III. Machining Process ..... 81

Instructions of Equipment Maintenance and Repair ..... 82

I. Maintenance Overview ..... 84

1.1 List of Main Maintenance ..... 84

1.2 Lubrication ..... 87

1.3 Mechanical Part ..... 91

1.4 Air Source Section ..... 95

1.5 Cooling Water Circulation Loop ..... 96

1.6 Maintenance of electrical parts and electrical cabinets ..... 99

1.7 Maintenance and maintenance of external auxiliary equipment ..... 101



## Safety Notes

This Chapter explains the concept of safety, and indicates the measures that should be taken to avoid possible risks. The “Overview of Other Risks” includes the measures taken by users to avoid other risks.



**Tip:** Users must comply with the existing regulations of safety and accident prevention of each nation, as well as the safety regulations of each province and region.

Warning signs and danger signs:

Some actions may cause dangers during operation. Job description usually follows warning signs in the Instructions. Danger signs are set on the machine tool.







Warning signs include the following warnings:

**Danger:** Indicates there is severe harm. If it is not avoided, it may cause death or serious injury!!!



No.	Name	Label	Description
1	Anti-electric Shock Label		Warning: Indicates there is likely to cause dangerous situations. If it is not avoided, it may cause serious personal injury or great loss!
2	Careful extrusion label		Do not reach in during operation, and cut off the power before maintenance!
3	Prohibit users from inserting or removing optical fiber labels		Do not plug or unplug optical fibers!





4	Prohibit forklifts to insert labels		Prohibit forklifts to insert!
5	Shipping Mark		
6	Keep Upright Label		Please pay attention to this label on arrival and confirm that if the equipment is placed upside down.
7	Anti-reverse Label		Please pay attention to this label on arrival and confirm that if the equipment is seriously reversed or dumped.
8	Pay attention to the forklift label		The personnel are warned to pay attention to the forklift here.
9	Hoisting Label		The personnel are warned to pay attention to the hoisting location of the crane.



<p>10</p>	<p>Emergency Stop Label</p>		<p>The personnel are warned to pay attention to the emergency stop button here.</p>
<p>11</p>	<p>Label of Removing the Shipping Block and Rust Prevention Oil</p>		<p>The personnel are warned that it is required to remove the rust prevention oil, shipping block and hoisting ring before using.</p>
<p>12</p>	<p>No Unpacking Label</p>		<p>The personnel are warned of not packing the boxes.</p>



## I. Overview

Please understand the content of this chapter before reading the manual.

This chapter shows you the intended readers, symbols, terms, abbreviations, expression rules and product conformity in the manual.

### 1.1 Scope of application



The manual is applicable to model i series fiber laser cutting machine.

### 1.2 Signal words

In the manual, the following safety signs identify important warning messages. When you see these sign, be alert to possible injuries, carefully read message on the right of the sign and inform other users in time.

The signal words are shown in Table 1-1 from high to low by risk level.

Table 1-1 Explanation of signal words

Sign	Signal word and explanation
	This signal word indicates a hazard with a high level of risk which, if not avoided, will result in death or serious injury.
	This signal word indicates a hazard with a medium level of risk which, if not avoided, could result in death or serious injury.
	This signal word indicates a hazard with a low level of risk which, if not avoided, could result in minor or moderate injury.

When more than one risk level occurs, use the highest level. When a signal word contains a warning message that may cause personal injury, a warning message of possible property damage may also be attached.

### 1.3 Intended readers



The manual addresses the following skilled users:

- Delivery personnel
- Installation personnel
- Operator
- Maintenance personnel

 <b>WARNING</b>	<p>Read <i>Safety</i> instructions before working for all people allowed to use the machine</p>
--	---

## 1.4 Terms

The terms and explanation used in the manual are shown in Table 1-2.

Table 1-2 Terms and explanation

No.	Term	Explanation
1	Plate machine	Machine for cutting rectangular plates, special-shaped plates and other plates.
2	Tube machine	Machine for cutting tubes such as round tubes and square tubes.

## 1.5 Abbreviations

The abbreviations used in the manual are shown in Table 1-3.

Table 1-3 Abbreviations

No.	Abbreviation	Full name
1	AC	Alternating Current
2	DC	Direct Current
3	HMI	Human Machine Interface



4	PLC	Programmable Logic Controller
---	-----	-------------------------------

## 1.6 Unit of measurement

The quantities in the manual are indicated in international standard units (SI Units). The units of measurement in the manual are the same as those on the machine.

## 1.7 Explanation of illustrations

For a better understanding of the manual, the illustrations in the manual are only for a brief description, in which the protective devices and covers may be removed. In the manual, Bodor Laser does not provide specific dimensions of the machine.

## 1.8 Conformity of machine

The machine is designed and manufactured according to the standards in Table 1-4.

Table 1-4 Reference standards

No.	Standard
1	Directive 2006/42/EC(Only CE standards apply)
2	EN ISO 12100: 2010 Safety of machinery - General principles for design - Risk assessment and risk reduction
3	EN 60204-1:2018 Safety of machinery - Electrical equipment of machines Part 1: General requirements
4	Directive2014/30/EU(Only CE standards apply)
5	EN IEC 61000-6-4:2019 Generic standards - Emission standard for industrial environments
6	EN IEC 61000-6-4:2019 Generic standards - Immunity for industrial environments
7	IEC 60825-1:2014 Safety of laser products - Part 1: Equipment classification and requirements
8	ISO 11553-1:2020 Safety of machinery - Laser processing machines - Part 1: Laser safety requirements



## II. Safe operation of equipment

### 2.1 Basic safety rules

Most accidents happen because basic safety rules are not followed.

The safeguards provided by Bodor Laser are only for basic accident prevention, only when safety working procedures made by the proprietor are provided simultaneously, the machine can be operated and maintained safely.

The proprietor of the machine must ensure that:

- 1) The safety regulations are posted in the respective working area;
- 2) Those persons who are concerned have been trained for their particular job and in regard to the safety regulations;
- 3) The safety regulations are adhered to.

In order to give full play to the performance of the machine without personnel injury and machine damage, users must obey the following basic safety rules:

- 1) The machine must only be used for the purpose it has been designed for, refer to 2.3 *Intended use and reasonably foreseeable misuse*. Do not use the machine exceeding the limits established by the technical data. Do not use the machine in a potentially flammable and/or explosive environment.
- 2) Operators must be qualified and authorized personnel who got safety and skill training. Maintenance of the machine should be carried out only by skilled persons who got specialized maintenance training of the machine. The work of the electrical system should be carried out by skilled electricians in accordance with applicable electrical engineering rules. These users should be able to fully comply with safety rules and preventive measures designed to prevent personal injury or machine damage.
- 3) Before using the machine, users must read the manual carefully, especially *Safety instructions* and all safety labels on the machine (refer to *Residual risks and safety labels*). Users must ensure that they fully understand the meanings and strictly



follow its requirements, all recommended safety protection measures and "common sense", otherwise it will cause personal injury or machine damage.

- 4) For safety, wear appropriate personal protective equipments (PPE) in accordance with local safety regulations and company safety rules. When using the machine, the operator should wear safety shoes, protective gloves, protective glasses, protective masks, do not wear loose clothing, fasten the cuffs and tighten the hair. Do not wear rings, watches, bracelets, ties, scarfs and other accessories.

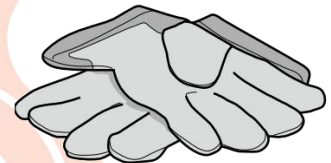

- 5) Before any operation, focus on what you want to do. Do not operate and maintain the machine after drinking or taking medicine. These conditions are critical to your safety.
- 6) Maintain good lighting conditions, a clean environment and sufficient working space to facilitate the operation and maintenance of machines and control cabinets.
- 7) Make sure that all safety protection measures are in place and maintained in effective working states before the operation, otherwise do not operate and maintain the machine, and immediately notify the superior. Do not suspend, move, modify or remove the safeguards or control devices of the machine at any time.
- 8) According to the noise test requirements specified in the EN ISO 11553-1-2020 standard, the A-weighted sound pressure of the main work stations of this machine is less than 70dB (A).



## 2.2 Machine nameplate

The machine nameplate is shown in Figure 2-1.

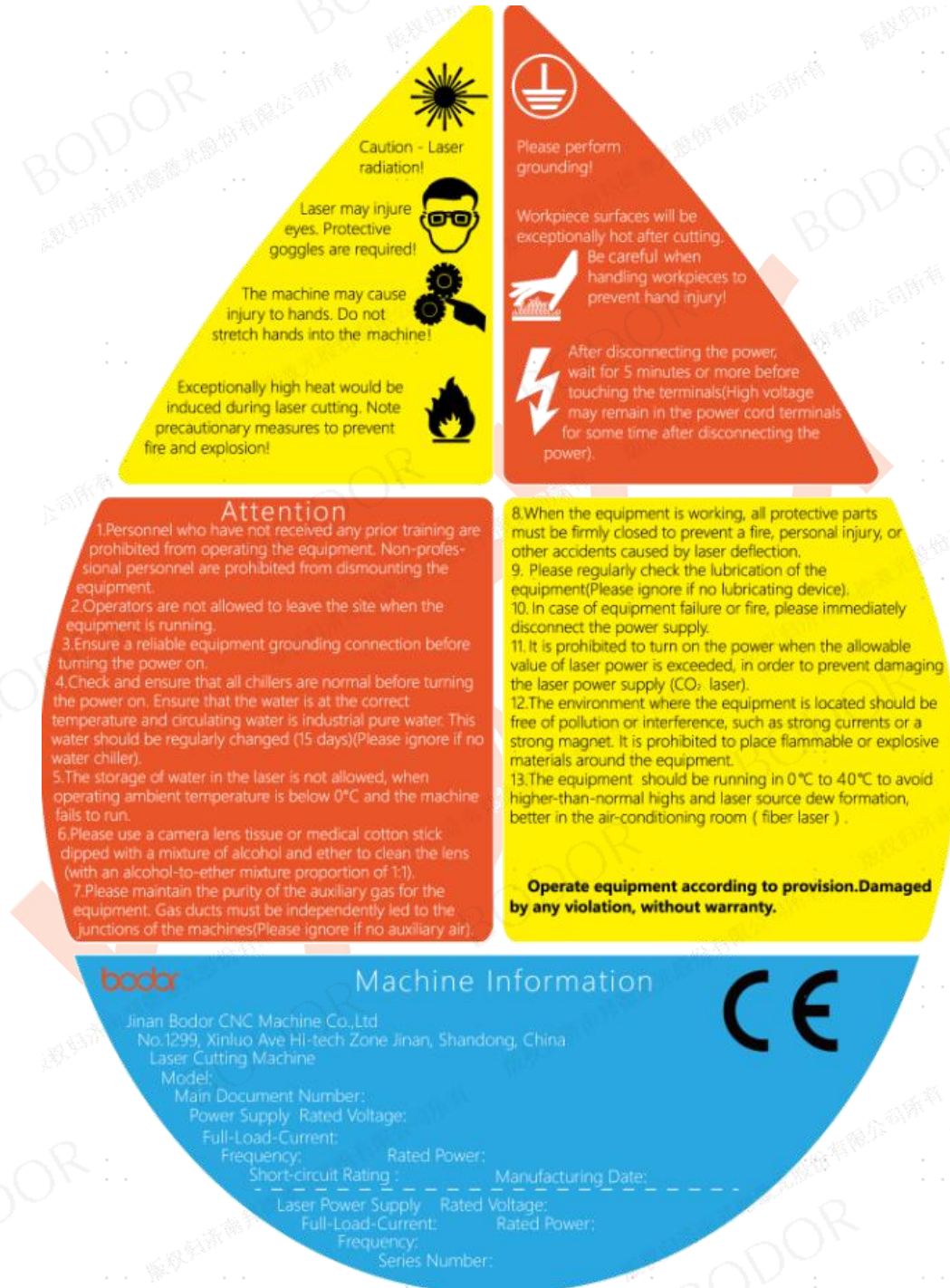



Figure 2-1 Machine nameplate





### 2.3 Intended use and reasonably foreseeable misuse

Laser cutting machine is designed and manufactured for cutting process of carbon steel, stainless steel, aluminum and copper plates and carbon steel, stainless steel tubes. The machine should be used by personnel who fully know machine risks and have strong safety awareness. Laser cutting machine is made referring to the latest technology and safety standards. However, it may cause harm to the lives and limbs of users or third parties, or cause damage to machines and other property. Therefore, any disfunction that affects machine safety should be corrected immediately.

 <b>WARNING</b>	<p>Users must follow the requirements in the manual.</p> <p>It is dangerous to use the machine for function beyond intended use. In this case, users are fully responsible for the risk, Bodor Laser will not be responsible for any injury caused thereby. This includes but is not limited to the following:</p> <p>Do not use the machine exceeding the limits established by the technical data;</p> <p>Do not use machine beyond permitted materials, such as rubber, plastic, glass, wood, magnesium, and sheets with PVC film.</p>
--	---

### 2.4 Operation positions

The operation positions of the machine are shown in Figure 2-2.

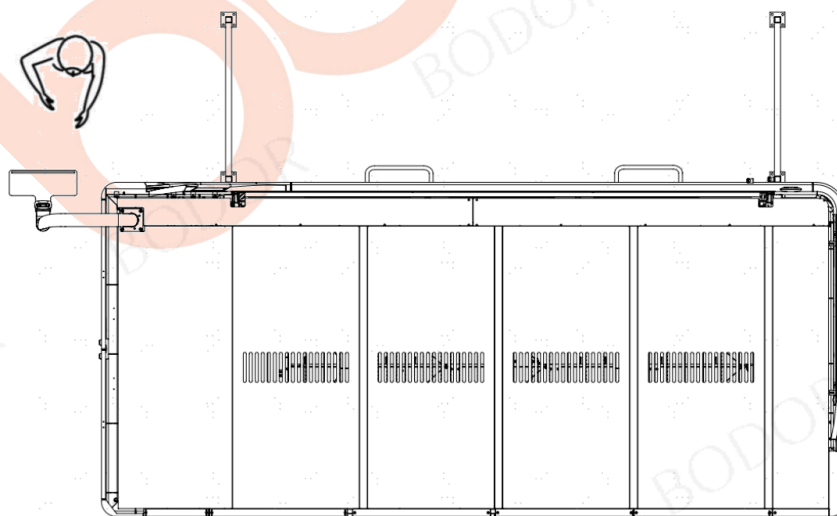





Figure 2-2 Operation positions

## 2.5 Operation environment

	<p>The machine is limited to be used in the following environments!</p> <p>Operations beyond the environments may bring greater risks or affect the machine's function and performance.</p>
---	---

Indoor use. Note: Avoid thermal deformation caused by direct sunlight on one side or wind on one side (for example, blinds can be installed when installing in the window position to avoid these situations).

Ambient temperature: 5°C ~ 40°C。 (For very hot and cold environments, additional requirements are required) .

Relative air humidity: ≤70%.

Atmospheric pressure: 86KPa ~ 106KPa.

Vibration isolation, no corrosive medium, no strong magnetic field interference, dust degree ≤ 2mg/m<sup>3</sup>.

It is recommended that capable users provide a constant temperature and humidity environment for the equipment.

No conductive dust and corrosive gases that damage insulation.

No vibration, shock and radiation affect the machine. **When there are electric welding and electric discharge machines nearby, the equipment must be powered off and cannot continue to work, otherwise Bodor Laser will not be liable.**

No potential flammable and/or explosive environment.

Make sure that there are no particles or substances that can absorb rays with a wavelength of 1.064μm around the machine.

For example, solvent-containing steam emitted during painting, or steam emitted from degreasing equipment.

Avoid the water cooler environment close to the dew point to avoid equipment damage.

The dew point temperature refers to the temperature at which the air is cooled to saturation without changing the water vapor content and air pressure. To put it vividly, the temperature at which the water vapor in the air turns into dew is called the dew point temperature, as shown in Table 2-1.



Table 2-1 Comparison Table

Relative HumidityΨ(%)	30	35	40	45	50	55	60	65	70	75	80	85	90	95
Environment Temperature Ta(°C)	Dew Point Td(°C)													
10	-7	-5	-3	-1.3	0	1.5	2.5	3.6	4.8	5.8	6.7	7.6	8.4	9.2
11	-6.5	-4	-2	-0.5	1	2.5	3.5	4.8	5.8	6.7	7.7	8.6	9.4	10.2
12	-5	-3	-1	0.5	2	3.3	4.4	5.5	6.7	7.7	8.7	9.5	10.9	11.2
13	-4.5	-2	-0.2	1.4	2.8	4.1	5.3	6.6	7.7	8.7	9.6	10.5	11.4	12.2
14	-3.2	-1	0.7	2.2	3.5	5.1	6.4	7.5	8.6	9.6	10.6	11.5	12.4	13.2
15	-2.3	-0.3	1.5	3.1	4.6	6	7.3	8.4	9.6	10.6	11.6	12.5	13.4	14.2
16	-1.3	0.5	2.4	4	5.6	7	8.3	9.5	10.6	11.6	12.6	13.4	14.3	15.2
17	-0.5	1.5	3.2	5	6.5	8	9.2	10.2	11.5	12.5	13.5	14.5	15.3	16.2
18	0.2	2.3	4	5.8	7.4	9	10.2	11.3	12.5	13.5	14.5	15.4	16.4	17.2
19	1	3.2	5	6.8	8.4	9.8	11	12.2	13.4	14.5	15.4	16.5	17.3	18.2
20	2	4	6	7.8	9.4	10.7	12	13.2	14.4	15.4	16.5	17.4	18.3	19.2
21	2.8	5	7	8.6	10.2	11.7	12.9	14.2	15.3	16.4	17.4	18.4	19.3	20.2
22	3.5	5.8	7.8	9.5	11	12.5	13.8	15.2	16.3	17.3	18.4	19.4	20.3	21.2
23	4.4	6.8	8.7	10.4	12	13.5	14.8	16.2	17.3	18.4	19.4	20.4	21.3	22.2
24	5.3	7.7	9.7	11.4	13	14.5	15.8	17	18.2	19.3	20.4	21.4	22.3	23.1
25	6.2	8.6	10.5	12.3	14	15.4	16.8	18	19.1	20.3	21.3	22.3	23.2	23.9
26	7	9.4	11.4	13.2	14.8	16.3	17.7	19	20.1	21.2	22.3	23.3	24.2	25.1
27	8	10.3	12.2	14	15.8	17.3	18.7	19.9	21.1	22.2	23.2	24.3	25.2	26.1
28	8.8	11.2	13.2	15	16.7	18.1	19.6	20.9	22	23.1	24.2	25.2	26.2	27.1
29	9.7	12	14	15.9	17.6	19.2	20.5	21.3	23	24.1	25.2	26.2	27.2	28.1
30	10.5	12.9	15	16.8	18.5	20	21.4	22.8	23.9	25.1	26.2	27.2	28.2	29.1
31	11.4	13.7	15.9	17.8	19.4	20.9	22.4	23.7	24.8	26	26.9	28.2	29.2	30.1



32	12.2	14.7	16.8	18.6	20.3	21.9	23.3	24.6	25.8	27	28.1	29.2	30.1	31.1
33	13	15.6	17.6	19.6	21.3	22.9	24.2	25.6	26.8	28	29	30.1	31.1	32.1
34	13.9	16.5	18.6	20.5	22.2	23.8	25.2	26.5	27.7	29	29.5	31.1	32.1	33.1
35	14.9	17.4	19.5	21.4	23.1	24.6	26.2	27.5	28.7	29.9	31	32.1	33.1	34.1
36	15.7	18.1	20.3	22.2	24	25.7	27	28.4	29.7	30.9	32	33.1	34.1	35.2
37	16.6	19.2	21.2	23.2	24.9	26.5	27.9	29.5	30.7	31.8	33	34.1	35.2	36.2
38	17.5	19.9	22	23.9	25.8	27.4	28.9	30.3	31.5	32.7	33.9	35.1	36	37
39	18.1	20.8	23	24.9	26.6	28.3	29.8	31.2	32.5	33.8	34.9	36.2	36.8	38.1
40	19.2	21.6	23.8	25.8	27.6	29.2	30.7	32.1	33.5	34.7	35.8	36.8	38.1	39.1

Bodor recommends that you follow the following measures to extend the life of the laser:

- 1) In order to ensure a good operating environment for the laser, reduce the risk of condensation, reduce the frequency of failures, and extend the service life. For equipment with a power of 10,000 watts and above, customers are required to configure an air-conditioned room with lasers. The air-conditioned room should be spacious enough to allow easy access to internal maintenance. It can ensure that the minimum free gap around the laser is 1.0m. The air-conditioned room requires good heat preservation and sealing performance to provide a constant temperature and humidity environment for the laser. The temperature in the air-conditioned room is required to be  $\leq 28\text{ }^{\circ}\text{C}$  . Relative humidity  $\leq 50\%$ .
- 2) The water cooler should be placed in a different space from the laser. It is strictly forbidden to place the water cooler in the air-conditioned room of the laser.

**Disclaimer: The damage to the laser caused by the customer's failure to configure an air-conditioned room for the laser. The resulting losses and various expenses are borne by the customer and are not within the scope of Bodor Laser's responsibility.**



## 2.6 Energy requirements

### 2.6.1 Electrical power

The electrical power requirements of the machine are shown in Table2-2.

Table 2-2 Electrical power requirements

Voltage	Nominal voltage AC380V Steady state voltage: 0.9 to 1.1 of nominal voltage.
Grounding system	3P+N+PE
Frequency	Nominal frequency 50Hz, 0.99 to 1.01 of nominal frequency continuously, 0.98 to 1.02 short time.
Harmonic	Harmonic distortion not exceeding 12% of the total r.m.s. voltage between live conductors for the sum of the 2nd through to the 30th harmonic.
Unbalanced voltage	Neither the voltage of the negative sequence component nor the voltage of the zero sequence component in three-phase supplies exceeding 2% of the positive sequence component.
Voltage interruption	Supply interrupted or at zero voltage for not more than 3 ms at any random time in the supply cycle with more than 1000ms between successive interruptions.
Voltage drop	Voltage dips not exceeding 20 % of the rms voltage of the supply for more than one cycle with more than 1000ms between successive dips.
Surge protective devices (SPDs)	SPDs should be provided in the power supply system by end-user, to protect against the effects of overvoltages due to lightning or switching surges.

**If the power quality does not meet the above configuration, a voltage stabilizer must be added to ensure normal operation of the equipment. Bodor Laser is not liable for losses caused by the quality of the power supply, especially property losses, personal injuries and production losses. Such risks are entirely borne by the user.**

**The configured transformer/stabilizer is only used for this machine, and it is forbidden to supply external power to other equipment.**



## 2.6.2 Air supply

 <b>CAUTION</b>	Laser cutting machine needs to be equipped with a separate air compressor.
--	--

The requirements of the air compressor are shown in Table 2-3.

Table2-3 Air compressor requirements

	Low power	High power	Ultra high power
<b>Pressure</b>	1.6MPa	1.6MPa	1.6MPa
<b>Flow</b>	1.5m <sup>3</sup> /min	2.6m <sup>3</sup> /min	3.7m <sup>3</sup> /min
<b>Pressure dew point</b>	2 ~ 8°C	2 ~ 8°C	2 ~ 8°C
<b>Filtration accuracy</b>	0.01µm	0.01µm	0.01µm
<b>Oil content of air outlet</b>	≤0.003ppm	≤0.003ppm	≤0.003ppm

The gas quality complies with ISO 8573-1:2010 standard requirements, solid particles-grade 2, water-grade 4, and oil-grade 3. It is required to be clean, free of water, oil and other impurities. It is used for thin carbon steel and thin stainless steel where conditions permit.

**Disclaimer: The use of compressed air below the above requirements will cause irreversible pollution to the machine tool pipeline, air valve and cutting head. The resulting losses and various costs are borne by user and are not within the scope of Bodor Laser's responsibility.**

## 2.7 Residual risks and safety labels

### 2.7.1 Residual risks

The residual risks of the machine are as follows.



 <b>WARNING</b>	<ol style="list-style-type: none"> <li>1) The rupture of pneumatic system air pipe will cause actuator such as cylinder to move.</li> <li>2) Even if the main power switch is in the "OFF" position, the power supply line and main power switch incoming terminals are still live.</li> <li>3) Even if the main power switch is in the "OFF" position, servo drivers, frequency converter and switching power supply may still be live</li> <li>4) Burn hazards arising from the surface temperature of servo driver and frequency converter heatsink.</li> <li>5) The surface temperature of the newly cut workpiece is high, which may cause burns.</li> </ol>
--	---

### 2.7.2 Safety labels

Safety labels give informations of the machine's potential risks. Before operation, be familiar with all safety labels.

The layouts of safety labels are shown in Figure 2-3.

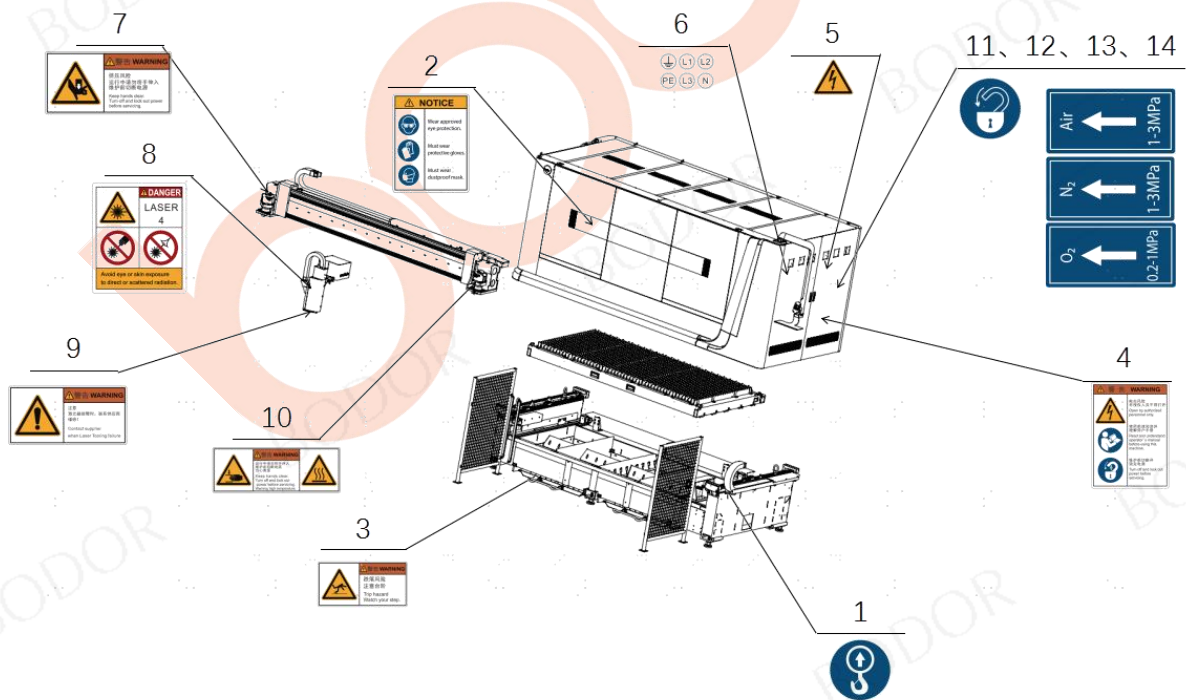

Figure 2-3 Safety labels layout



The descriptions of safety labels are shown in Table 2-4.

Table 2-4 Safety labels

No.	Position	Safety label	Description
1	Lifting point		Machine lifting point
2	Cover observation window		<p>Class 1 laser products.</p> <p>Laser beams available are not dangerous under predictable proper conditions.</p> <p>Must wear approved eye protection.</p> <ul style="list-style-type: none"> <li>• Must wear approved eye protection.</li> <li>• Must wear protective gloves.</li> <li>• Must wear dustproof mask.</li> </ul>
3	Trolley at bottom of cover		When the trolley is pulled out, there is a tripping hazard.
4	Control cabinet door		<p>Open by authorized personnel only.</p> <p>Read and understand operator's manual before using this machine.</p> <p>Turn off and lock out power before servicing.</p>
5	In control cabinet		Risk of electric shock





6	In control cabinet		Wiring instructions
7	Beam		<p>Squeeze risk</p> <p>Do not put your hand in during operation</p> <p>Cut off the power before maintenance</p>
8	Laser head		<p>Class 4 laser products</p> <p>Avoid eye or skin exposure to direct or scattered radiation</p>
9	Laser head		Contact supplier when Laser Tooling failure
10	Motor base		<p>Burn hazard</p> <p>Hot surface</p> <p>Do not touch</p>
11	Air source position		Turn off and lock out air power before servicing
12	Main air source pressure and flow direction		Air pressure and flow direction
13	Nitrogen main source pressure and flow direction		Air pressure and flow direction



14	Main oxygen source pressure and flow direction		Air pressure and flow direction
----	--	---	---------------------------------

Make sure that all safety labels are clear and legible. Clean or replace the safety labels if you cannot read.

When cleaning safety labels, use a cloth, soapy water. Do not use solvents, gasoline, or other harsh chemicals. Solvents, gasoline, or harsh chemicals could loosen the adhesives that secures the safety labels.

Replace any damaged or missing safety labels. If safety labels are attached to the part to be replaced, paste same safety labels on the new replacement part.

### 2.8 Safeguards

The safeguards are shown in Figure 2-4.

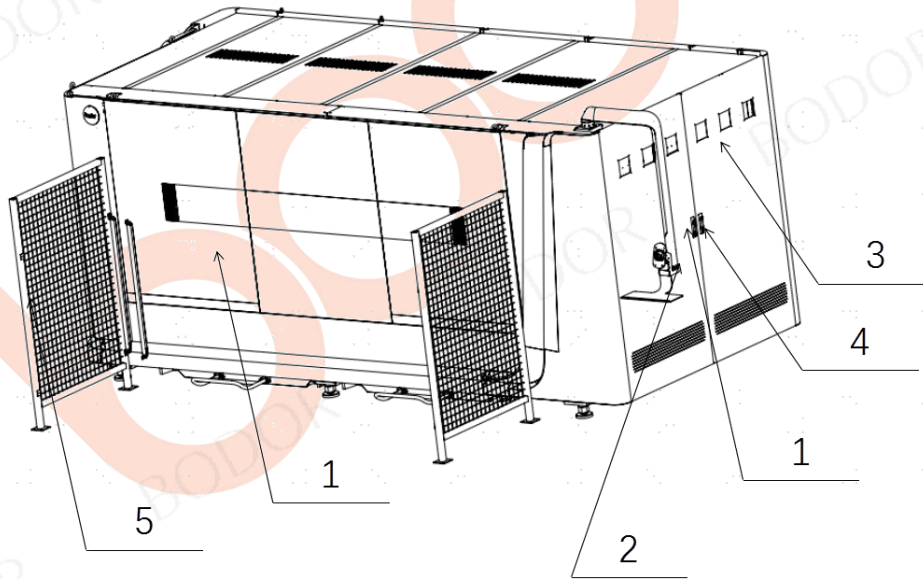

Figure2-4 Safeguards layout

Table 2-5 describes the safety protection devices.



Table 2-5 Safeguards functions

No.	Safeguard	Description
1	Safety door switch	Open safety door, machine stops urgently. Close safety door and press "RESET" button on side of touch screen to reset safety system.
2	Emergency button	Press emergency button and machine stops urgently. Rotate to release emergency button and then press "RESET" button on side of touch screen to reset safety system.
3	Safety door switch	Open safety door, machine stops urgently and power off.
4	Main power switch (with keyhole)	Turn on/off main power of machine, turn off main power and lock it before maintenance.
5	Safety light screen	The safety light screen is triggered and the operation is stopped. Press the "reset" button on the side of the touch screen to restore the security system.

Please note that in safety protection devices that stop button is only CE standard configuration, GB is optional.

**Safety instructions related to safeguards:**

	<ol style="list-style-type: none"> <li>1) Make sure that safety protection measures are in place and maintained in effective working state before operation.</li> <li>2) Do not suspend, move, modify or remove the safeguards or control devices of the machine at any time.</li> </ol>
---	--



- 1) The safety protection measures taken by the machine can only reduce but not completely eliminate all risks.
- 2) Check the functions of emergency button and safety light curtain every 72 hours.
- 3) Check the functions of main power switch and safety door switch every 168 hours.
- 4) After any maintenance work of removing safety door or other safety protection devices, reinstall these devices, check whether they are functioning properly, and ensure that they are in the correct position and in an effective working state.
- 5) Check the necessary safety functions after replacing any safeguards.
- 6) Operator should know the position and operation method of emergency stop devices to stop the machine in case of emergency.
- 7) Do not stop the machine during usual operation by emergency stop devices.

## 2.9 Safety instructions for machine lifecycle

During the transportation, installation, operation, adjustment, maintenance and disassembly of the machine, users should obey the basic safety rules described in the manual, the safety regulations in your country/region and safety preventive measures as follow.

**Disclaimer: Any operation outside of this regulation is regarded as a non-compliance use, and Bodor Laser is not responsible for the losses caused thereby, especially property losses, personal injuries and production losses. Such risks are entirely borne by the user.**

### 2.9.1 Transportation

For personal safety and machine transportation safety, delivery personnel should obey the following safety rules besides 2.1  
*Basic safety rules:*

- 1) Provide suitable storage conditions to prevent machine damage. The storage temperature should be between  $-25 \sim +55^{\circ}\text{C}$ , and for short periods not exceeding 24 h at up to  $+70^{\circ}\text{C}$ .
- 2) Only qualified and authorized personnel who got safety and skill training can transport the machine;



3) Refer to machine mass shown in *5.3 Transportation* and use lifting equipment with sufficient capacity. Only use the lifting points shown in *5.3 Transportation*.

4) Avoid sudden movement during machine moving.

## 2.9.2 Installation

For personal safety and machine transportation safety, installation personnel should obey the following safety rules besides

*2.1 Basic safety rules:*

- 1) Only qualified and authorized personnel who got safety and skill training can install the machine;
- 2) Before installation, check if
  - No part of the machine is damaged;
  - No water leakage in the control cabinets, operation panels and junction boxes;
  - Internal pipeline connection is firm and mechanical connection is reliable.
- 3) The machine should be reliably grounded. Before connecting the live conductors of power cable to the machine, ground the machine first. The plate machine is grounded separately, tube machine is grounded separately, control cabinet is grounded separately, and peripheral equipment (laser, water cooler, transformer, voltage stabilizer, fan, smoke purifier, etc.) is separately grounded. Grounding resistance is required to be  $\leq 4\Omega$ ;
- 4) PE terminal, the protective conductors in the equipment of the machine, conductive structure parts and exposed conductive parts and conductive structure parts of the machine should be interconnected.
- 5) Connect the protective bonding circuit to accessible extraneous conductive parts (such as metallic pipes, fences, ladders and handrails) in the vicinity of the machine.
- 6) After installation, verify the continuity of the protective bonding circuit by professional personnel equipped with test instruments.
- 7) Static elimination device shall be provided by the end-user for such material roll which undesirable electrostatic may discharge.



### 2.9.3 Operation and adjustment

For personal safety and machine operation safety, operators should obey the following safety rules besides *2.1 Basic safety rules*:

- 1) Only qualified and authorized personnel who got safety and skill training can operate and adjust machine. This applies not only to the machine operator, but also to all those who may be involved in the machine operation in some way.
- 2) The key of the mode-select key switch should be kept by authorized person in charge.
- 3) The HMI password should be kept by authorized person in charge.
- 4) Any function adjustment of the machine must be performed when the machine is stopped.
- 5) Always keep hands, arms or other body parts away from moving parts of the machine. Do not reach into areas of dangerous moving parts or use tools to increase the accessibility of the areas.
- 6) Never climb or rest against the machine at any time.
- 7) Before starting the machine, make sure none is working on or around the machine and remove all irrelevant items on the workstation.
- 8) The machine should be operated by a single person.
- 9) Do not handle material over 25kg by a single person. When the mass of material is greater than 25kg, two persons lift together or use auxiliary equipment which should be provided by the user.
- 10) When changing the material from aluminum/aluminum alloy to other metal materials (and vice versa), you must wait for the dust removal device to run for a period of time before it can work. It is best to clean the filter element in the fume purifier once (if the equipment is equipped). When conditions permit, special filter elements are used for each type of material.
- 11) Use suitable tools to take out high temperature workpieces.



- 12) In case of serious failure of the water chiller (such as leakage of the coolant circulation circuit), the water chiller must be shut down immediately.
- 13) Do not use machine when dust removal system is not working.
- 14) Place a dry powder fire extinguisher next to machine to prevent fire hazards caused by thermal residues generated during laser processing; place a CO<sub>2</sub> fire extinguisher to prevent fires caused by other reasons.
- 15) Do not allow cigarettes or other burning materials to enter the inside of the machine.
- 16) Do not allow cigarettes or other burning materials to enter the inside of the machine.
- 17) After emergency stop or failure, the machine should be checked by authorized personnel before restarting.
- 18) After stopping the machine under safe conditions, remove debris or other foreign matters from the machine and nearby.
- 19) Where whole body access is possible, can enter, person who leaving danger zone needs to look that there is no person in the danger zone and to operate the reset switch before starting the machine.
- 20) After the production is finished, stop the power supply

## 2.9.4 Maintenance

For personal safety and machine maintenance safety, maintenance personnel should obey the following safety rules besides

### 2.1 Basic safety rules:

- 1) Only qualified and authorized personnel who got safety and skill training can do maintenance work.
- 2) Sufficient local lighting must be provided if maintenance or inspection requires access into the machine.
- 3) Maintenance signs must be placed around the maintenance area to warn the maintenance is in progress.
- 4) Before starting any maintenance work, make sure that the machine is completely stopped, turn main power switch to "OFF" position and lock it, and turn main air source switch to "OFF" position and lock it.



- 5) Do regular maintenance and inspections of machine in accordance with the requirements in 8 Maintenance.
- 6) Even if the main power switch is in the "OFF" position, the following parts and their conductors are still live!
  - Power supply line and main power switch incoming terminals are still live.
  - Servo drivers, frequency converter and switching power supply may still be live within 20 minutes after power off. Do not touch their parts and the conductors connected to them.
- 7) Do not move the positions of safeguards. Otherwise, Bodor Laser will not be responsible for repair or any damage caused thereby.
- 8) Take safety preventive measures in the manual to prevent personal injury or machine damage when doing maintenance work.
- 9) Reinstall the safeguards and make sure them in correct position and effective working states after removing the safeguards for maintenance purpose.
- 10) Use the parts and materials confirmed by Bodor Laser when replacing new parts.
- 11) Any technical modification of the machine must be done by Bodor Laser or with the confirmation of Bodor Laser.

## 2.10 Laser safety

Laser equipment is broken down into different laser classes according to the European standard EN 60825-1, laser class indicates the hazard level of laser beam irradiated, as shown in Table 2-6.

Table 2-6 Laser classes

Laser class	Description
1	Laser beams available are not dangerous under predictable proper conditions.





2	<p>The wave length of laser beams available is within the visible spectrum range (400nm-700nm).</p> <p>Short-time exposure (less than 0.25s) does not damage the eyes. For other rays beyond the wave length range of 400-700nm which meet Class 1 conditions, generally can protect the eyes by keeping away from laser beams or closing eyes.</p>
3B	<p>Laser beams available are harmful to the eyes and skin as well. It is very dangerous to look straight at rays of a 3B laser. Exceeding the maximum allowable radiation value, rays from the 3B laser source may cause damage to the skin.</p>
4	<p>Rays available are extremely harmful to the eyes and skin, and even diffused rays also cause damage. And rays may cause a fire and explosion hazard.</p> <p>For a class 4 laser device, safety measures must be taken: The most important is to fully protect the eyes. Under normal circumstances, the power intensity of a Class 4 laser device is enough to burn the skin, cause a fire and ionize the atmosphere when focusing. Therefore, a series of other security measures should be taken.</p>



The laser level is different under different machine operating modes. The operating modes of the laser cutting machine are shown in Table 2-7.

Table 2-7 Operating modes

Mode	Description	State	Class
Normal operation mode	Normal operation mode refers to the operation of the equipment within the range of all functions.	Machine is controlled by program or manually. Personnel are outside the danger zone.	1
Maintenance and debug mode	Maintenance and debug mode refers to state of machine during maintenance and debugging.	When the equipment is in an abnormal state or needs to be maintained.	4

The danger of laser rays.



	<ol style="list-style-type: none"> <li>1) The laser beam in operation is high-energy, invisible light!</li> <li>2) It may severely burn the skin and hurt the eyes. The impact on vision can cause vision damage and even blindness!</li> <li>3) If you are debugging while the laser is working, you must wear laser protective glasses.</li> <li>4) Thermal residues generated during laser processing can easily cause fire hazards.</li> </ol>
	<ol style="list-style-type: none"> <li>1) Laser rays can hurt eyes! Do not look directly at the rays!</li> <li>2) If you look at the processing position for a long time, visible rays may cause injury to the operator. Especially in high-speed cutting, or processing such as galvanized steel, aluminum and high-quality steel, the plasma generated will produce bright and strong light, which may cause permanent damage to the retina.</li> <li>3) The secondary rays during laser processing are dangerous! High-intensity visible rays can cause permanent damage to the retina!</li> <li>4) Do not look directly at the processing location without taking protective measures</li> <li>5) Wear laser protective glasses when needed.</li> <li>6) Cutting highly reflective materials can easily cause fire and may damage the laser and fiber, it is not recommended to cut for a long time.</li> </ol>

Disclaimer:

- 1) Any operation other than those regulated herein shall be considered as non-compliant use; any losses caused thereby, especially property damage, personal injury and production losses, shall be fully borne by the user.
- 2) Subject to the risk of laser-bounce during the laser cutting process, there should be no flammable and explosive products such as gasoline and styrofoam within 2 meters around the laser cutting machine to prevent fires, explosions and other disasters. Any losses caused thereby, especially property damage, personal injury and production losses, shall be fully borne by the user.
- 3) The protective devices and functions of the equipment itself must not be removed or discarded by the customer without permission. Any losses caused by the failure to observe this requirement, especially property damage, personal injury, production losses, shall be fully borne by the user.
- 4) The losses incurred by use of outsourcing parts or improper installation and replacement of spare parts or accessories



authorized by Bodor are not within the scope of Bodor Laser's liability.

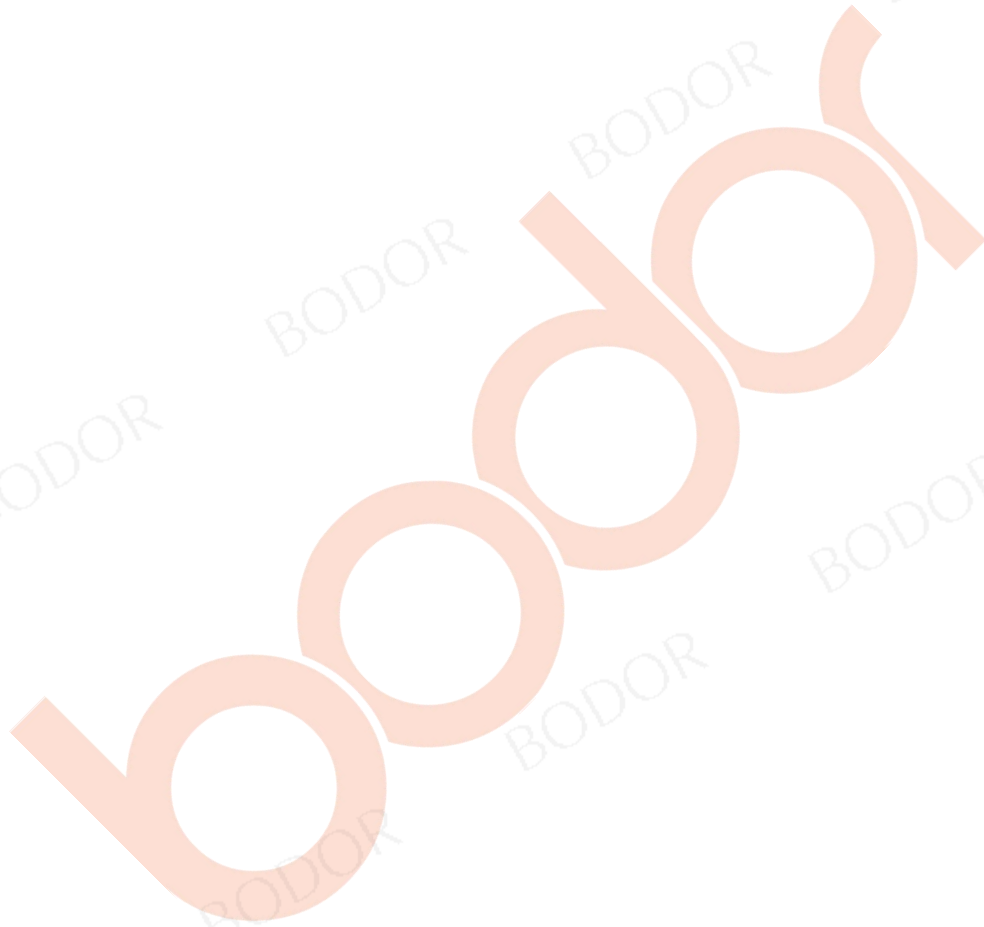



# Guide of Complete Machine Assembly and Disassembly

## Important notes

The guide of complete machine assembly and disassembly includes preparation and all other information for placement and use of the machine tool before use.

### Tip

**I series are the equipment with multiple models for cutting metal materials with laser, and it is not allowed to use the i series to cut non-metal materials (e.g. glass, acrylic, wood, etc.).**

### Tips

All the conditions described in this Chapter must be met before the arrival of the machine tool. Otherwise, the Bodor Laser's After-sales Service Department will not provide any services before the machine tool is put into operation. Please make all the preparations in advance according to the following work plans.

### Tips

Before the equipment officially runs, the machine tool should be operated only by personnel authorized by Bodor Laser or by Bodor Laser's after-sales service personnel.

### Tips

The initial debugging and running of the machine tool should be carried out only by Bodor Laser's debugging service personnel or customer service commissioners.

Include:

- 1) Place, calibrate, level correction and fix the machine tool.
- 2) Add the coolant.
- 3) Connect the machine tool to the supply system (except the power source).



- 4) Perform functional testing.
- 5) Instruct the operators.
- 6) The customer shall contact the customer service staff of Bodor to guide the move and disassembly of the equipment if the customer has this demand. Our company will not be responsible for the warranty if the equipment cannot work or does not work normally because it has not been moved or disassembled privately by the customer without contacting the customer service staff of Bodor!!

#### **Tips**

**It is required to ensure that the amount of lubricant is normal when the machine tool is running, and check it at regular intervals. The customer is required to perform regular maintenance according to the guide for maintenance points.**

**We will not be liable for any problem arising from the failure of maintenance.**



## I.Preparedness Plan

The preparedness plan provides the preparedness scheme required by the customer before the arrival of the equipment. See relevant chapters of the guide of complete machine assembly and disassembly for details. The time planning is for reference only, and the details are subject to the actual order.

Before the arrival of the equipment	Main points of the plan	Measures
10 <sup>th</sup> week before the arrival of the equipment	Installation site	<ol style="list-style-type: none"> <li>1) Determine the installation site of the machine tool, and at the same time consider the site requirements according to the site layout drawing.</li> <li>2) Check ground conditions: <ul style="list-style-type: none"> <li>•Ground quality</li> <li>•Flatness</li> <li>•Gap</li> </ul> </li> <li>3) Pay attention to machine weight and size.</li> <li>4) Check climatic conditions: <ul style="list-style-type: none"> <li>•Room temperature.</li> <li>•External air purity.</li> </ul> </li> <li>5) Check transport routes: <ul style="list-style-type: none"> <li>•Doorway size</li> <li>•Height of breast beam</li> <li>•Height of cable rack</li> <li>•Switchyard around the corner, etc.</li> </ul> </li> </ol>



8 <sup>th</sup> week before the arrival of the equipment	Personnel and training	<ol style="list-style-type: none"> <li>1) Appoint a person in charge of transfer and preparation of the machine tool.</li> <li>2) Assign operating personnel, maintenance personnel and programming personnel.</li> <li>3) Agree on the training period of professionals.</li> </ol>
4 <sup>th</sup> week before the arrival of the equipment	Power supply	<ol style="list-style-type: none"> <li>1) Install the electrical interface at the installation site.</li> <li>2) Prepare standard wiring and circuit protection according to the regulations.</li> </ol>
4 <sup>th</sup> week before the arrival of the equipment	Air compressor (only when prepared by the customer)	Install the compressed air feeder at the installation site.
2 <sup>nd</sup> week before the arrival of the equipment	Running materials	<ol style="list-style-type: none"> <li>1) Nitrogen,</li> <li>2) Oxygen</li> <li>3) Cooling water</li> <li>4) Compressed air (optional)</li> </ol>

## 1.1 Installation Conditions

### Requirements for ground

- 1) The ground of equipment installation should be flat, the flatness be within  $\pm 5\text{mm}$ , and the concrete thickness of the entire installation surface be not less than 200mm.

### Requirements for space

- 2) The distance between left side and rear side of the machine tool and the workshop wall should be more than 1,200mm; the distance from the laser to the wall should be more than 1,000mm.
- 3) In order to prevent the occurrence of a fire, the processing site should be equipped with appropriate fire extinguishers, and fire-fighting access should be set aside.
- 4) The detailed technical indicators are subject to the *Foundation Map* attached with our company.



## Tips

**For i series products, the foundation needs to be made pursuant to the requirements of foundation drawings (see the Annex *Foundation Drawings for i Series Products*). Bodor shall not be responsible for poor cutting accuracy of the equipment, ripples generated by cutting parts, waves and other phenomena due to the customer's failure to make the foundation according to the requirements!**

### Requirements for environment

- 1) The core parts of the machine tool, including the control unit, servo unit, monitor and control panel, have certain requirements for the environment. Protect the machine tool against interference from electromagnetic wave, When there are electric welding and electrical discharge machining nearby, the equipment must be powered off and cannot continue to work, failing which Bodor will not hold responsible.
- 2) In order to ensure cutting quality, it is necessary to ensure that there are no particles or substances which can absorb the ray with a wavelength of 1.064um around the machine, such as solvent vapor that is emitted during paint spraying or steam from a deoiler.
- 3) **In the electric control cabinet, the user shall neither connect external wires and sockets nor connect electric drills, angle grinders, etc. into the electric control cabinet, failing which Bodor shall not be liable for the damage to the components caused thereby.**

## 1.2 Power Supply

### Quality of power supply

- 1) Degree of three-phase unbalance <2.5%, line voltage fluctuation <5%.
- 2) If the quality of power supply does not meet the said configuration, a voltage stabilizer shall be added to ensure normal operation of the equipment, failing which any losses caused by the quality of power supply, especially property damage, personal injury, production losses and other risks, shall not be liable by Bodor. shall be solely borne by the user, for which Bodor shall not be liable.

### Ground protection

#### Grounding point:

- 1) The machine tool is grounded separately;





- 2) The electric control cabinet is grounded separately;
- 3) The peripheral equipment is grounded separately (laser, water cooler, transformer, voltage regulator, fan, smoke purifier, etc.); the grounding resistance is required to be  $<4\Omega$ .

Ground pile requirements:

The grounding device shall be made of steel. Which can use 50mm diameter steel pipe or 50mm×50mm×5mm angle steel. While pouring an appropriate amount of saline, the angle steel and steel pipe grounding body should be vertically arranged. A copper core cable of 10 mm<sup>2</sup> should be used as the grounding lead to ensure a good grounding effect, of which leads should be connected to the grounding body, and for the remaining equipment, it is required to use a copper core cable that is not less than the ground wire diameter of total power cord of the Equipment as the ground lead, with M12 bolts, and the bolted parts shall be supplemented with anticorrosive paint.

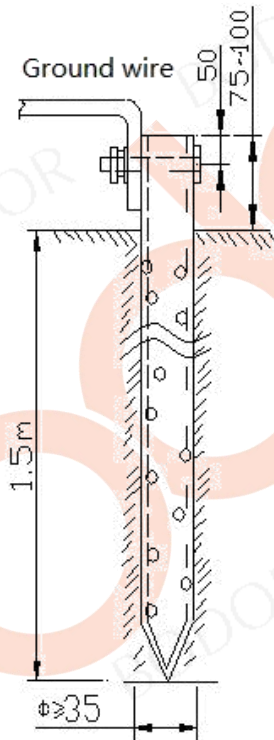

The grounding part of electrical equipment shall be connected to the grounding trunk with a separate ground lead.

In a grounding system, the grounding resistance shall be less than or equal to  $4\Omega$ , and the repeated grounding resistance shall be less than or equal to  $10\Omega$ .

The grounding resistance shall be measured at regular intervals (on a quarterly basis). In the case that the resistance value exceeds the standard, it is necessary to find out the cause and rectify without delay.

The transformer/voltage stabilizer configured in the equipment is only used for this equipment, and do not use external power supply for other equipment.

**Disclaimer: Any operation other than those regulated herein shall be considered as non-compliant use; any losses**



caused thereby, especially property damage, personal injury, production losses and other risks, shall be solely borne by the user, for which Bodor shall not be liable.





### 1.3 Running Materials

Gas quality in accordance with ISO 8573-1:2010; solid particles - grade 2, water - grade 4, oil - grade 3.

Nitrogen: Nitrogen with the minimum purity of 99.99% and the concentration < 100ppm is used to cut stainless steel.

Oxygen: Oxygen with the minimum purity of 99.9% and the concentration < 100ppm is used to cut carbon steel.

Compressed air: Compressed air should be clean, anhydrous, oil-free and have no impurities. It is used for thin carbon steel, slim stainless steel, etc. if conditions permit. (The key parameters of air compressor should not be lower than the standards following: Please choose screw air compressor as much as possible. The volume flow is related to the laser power. The maximum working pressure is  $\geq 1.6\text{mpa}$ , the pressure dew point is  $2\sim 8^{\circ}\text{C}$ , the filtration precision is  $0.01\mu\text{m}$ , and the oil content of air outlet is  $\leq 0.003\text{ppm}$ , Air cutting gas path input pressure  $\leq 3\text{Mpa}$ ; cooling gas input pressure  $0\text{-}0.5\text{Mpa}$ ).

**Disclaimer: Any oxygen, nitrogen and compressed air used that are inferior to the above requirements will cause irreversible pollution of pipelines, valves and cutting head of the machine tool; any losses and expenses caused thereby shall be borne by customers, for which Bodor shall not be liable.**

Lubricating oil: Please use liquid lubricating oil that meets the standard, and the No. 32 # lubricating oil is preferred.

Cooling water: Cooling circulating water should be high-quality non-mineral purified water, distilled water or deionized water.



## **II. Transport and Handling**

### **2.1 Requirements for Transport**

The laser cutting machine should be firmly fixed in transit to prevent damage. The packed product should be able to be transported to any place on the secondary road. During long-distance transportation (including sea transport, rail transport, road transport, etc.), the machine shall not be loaded in the open trunk or in the cabin, not allowed to be transported together with the inflammables, explosives, corrosives and other dangerous goods. It is not allowed to get wet due to rain, snow and liquid substances. Mechanical collision or damage is not allowed. Electrical equipment shall be designed to withstand  $-25^{\circ}\text{C}$   $\sim 55^{\circ}\text{C}$  storage and transport temperature, up to  $70^{\circ}\text{C}$ . The storage and transportation temperature of C should not exceed 24 hours. It is required to provide the appropriate methods to prevent excessive moisture, rocking, squeezing and mechanical collision of the goods during the process of transport.

### **2.2 Requirements for Handling**

All hauling operations should be carried out in accordance with transport regulations.

The machine tool shall not be placed on the ground without floor tiles; otherwise, the bottom of each component will be damaged! The base plate of the machine tool must be 100mm or more above from the ground, and such a distance must be also maintained when the machine tool is transported to the installation site.

The ground conditions of the installation site must meet the requirements of installation conditions. The user must provide the conditions for installation according to the layout drawing before the machine tool arrives.

When the equipment reaches the customer, the load capacity of lifting equipment required by unloading and transferring depends on the type of the product purchased by the customer.

When the equipment arrives at the customer, the unloading, unpacking and positioning of the equipment shall be conducted in strict accordance with the Equipment field installation operation guide of Bond Laser i7 model, and all tools shall be selected in strict accordance with the equipment field installation operation guide of Bond Laser i7 model.



## 2.3 Handling Tools

When unloading and transferring the equipment after its arrival, select auxiliary equipment according to the equipment on-site installation instructions of the corresponding models of Bodor Laser i series, such as forklift, crane, travelling crane.

If the crane or travelling crane is used, it is only allowed to hoist the position of the lifting ring with the hoisting label.

During the use of the forklift, special attention should be paid to avoiding the vulnerable parts of the equipment, such as sheet metal parts, to prevent the forklift from damaging the equipment. It is strictly prohibited to use a forklift for handling the equipment with relatively long overall length, uneven center of gravity that is easy to be dumped.

If conditions permit, the preferred choice is to use a forklift and a travelling crane to unload and transfer the equipment and its accessories to the designated location.

If there is no travelling crane line or its tonnage cannot meet the requirements in the plant, please select crane and forklift for unloading. And use appropriate transferring equipment and loading methods to deliver the laser cutting machine and its accessories to the designated location.

Under the conditions that the plant is small with no travelling crane. I :Cranes and forklifts are used to unload the equipment outside the plant for transfer. Tanks are placed at the front and bottom of the equipment bed, and forklifts are used to transport the equipment to the designated position at the back.

Under the conditions that the plant is small with no travelling crane. II : Crane and forklift are selected to unload the equipment outside the factory and then transfer it. The transportation tank is placed at the bottom of the front and back corners of the equipment bed, and it can be moved to the specified position using a crowbar. bed of the equipment; and move it to the specified location with crow bars.

### Warning

The equipment should be hoisted and handled by a professional transport company. If the customer needs to handle and hoist the equipment on his or her own, personnel in charge should receive professional training as well. If the customer changes the hoisting mode, Bodor Laser will not be liable for damage to the equipment and personal injury.



## 2.4 Hoisting Position and Forklifting Point of the Lathe Bed

(The following sketches are slightly different from each other according to different equipment, only for reference)

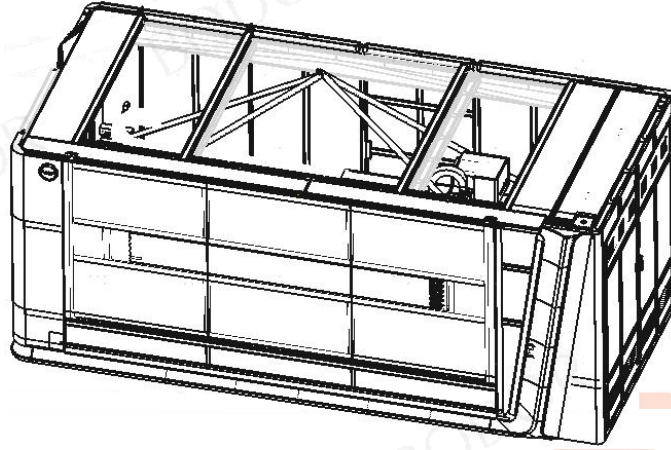

For detailed unloading steps, please refer to the *operation instruction for equipment on site positioning* and the *operation instruction for equipment on site installation*. Please unload according to our requirements, otherwise our company will not be responsible for any situation.

## 2.5 Storage Conditions, Period and Notes

The ambient temperature of the plant where the laser cutting machine is stored should be  $-10^{\circ}\text{C}\sim 40^{\circ}\text{C}$  with the relative humidity of 45%~85%. In the plant, different kinds of harmful gases, flammable and explosive products and corrosive chemicals are not permitted. The cooling water in the equipment must be drained without strong mechanical vibration, shock and strong magnetic field interference. The host equipment and packing box should be at least 100mm away from the ground. Outdoor storage is strictly prohibited. The storage period shall not exceed six months. If it is stored for more than six months, a full inspection is required. Only after passing the inspection can the equipment be used.



# Installation and Debugging Guide

## I. Brief Introduction to the Structure

### 1.1 Composition of Complete Machine

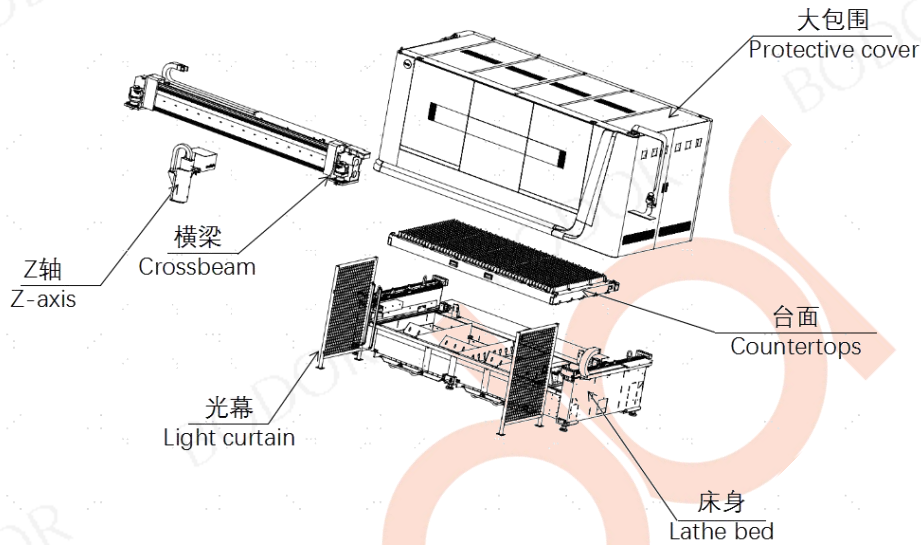

### 1.2 Introduction to Important Components

#### 1.2.1 Lathe bed

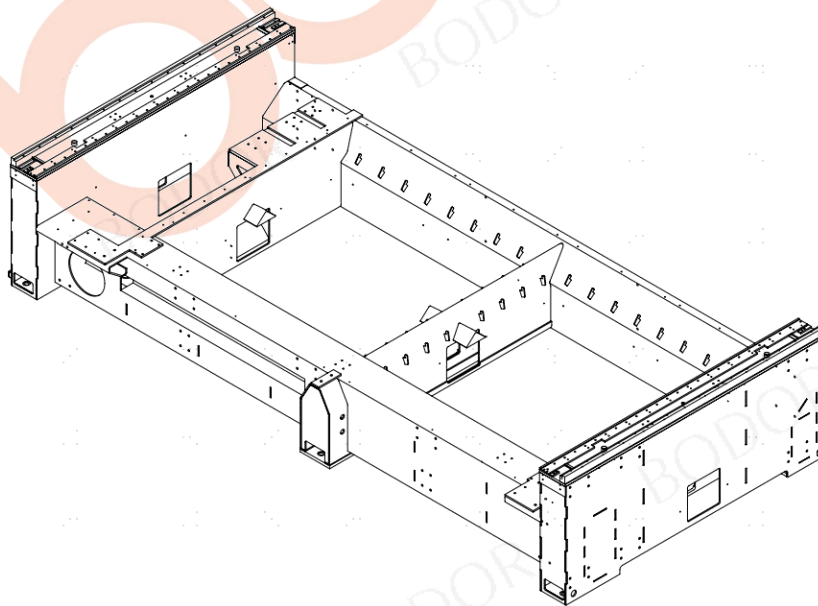



The bed is welded with high strength carbon steel plate with high rigidity, stability and impact resistance.

Bed guide mounting surface, motor seat mounting surface, beam mounting surface and other dimensions of a clamping process, improve the machining accuracy, while ensuring a higher cutting accuracy.

### 1.2.2 Crossbeam Components

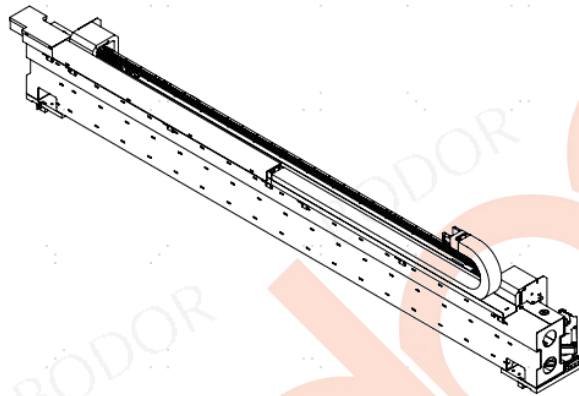

The motion unit is based on the beam assembly with high stability. The cross beam is made by extruding the overall casting of reinforced aluminum alloy through heat treatment, and subject to heat treatment and other technologies, which can ensure the strength requirement. At the same time, the beam adopts lightweight design to improve the cutting speed. The beam is mounted with high-precision linear guide rail and gear rack transmission mechanism, so that the cutting head can move back and forth in the Y direction. Switches and buffer blocks are set on both ends of the stroke to achieve double protection of action.

### 1.2.3 Countertops



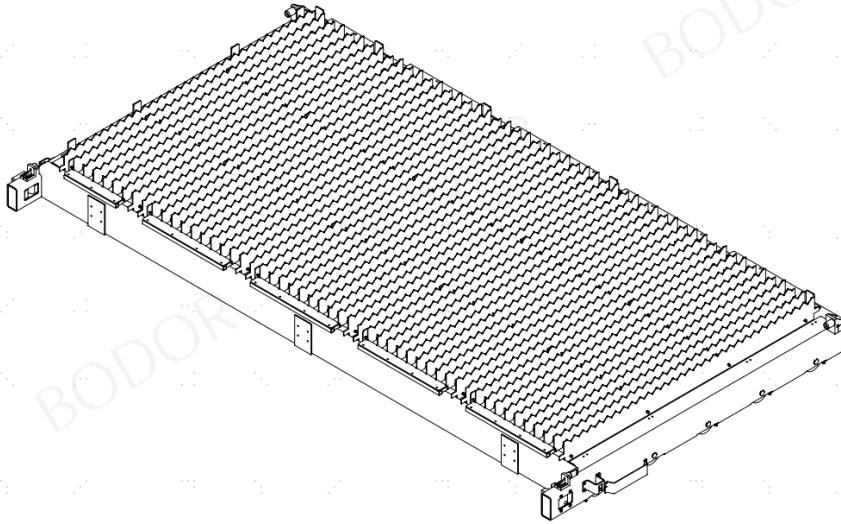

I model work table standard with fixed table, table adopts modular bottle structure, with good strength and stability, compact structure, more convenient replacement disassembly.

#### 1.2.4 Z-axis Device

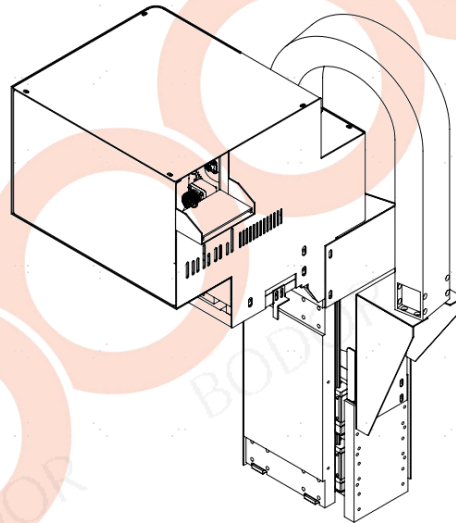

Z-axis device is an integral part to ascend and descend the cutting head, and the vertical movement of the cutting head is controlled by computerized numerical control system servo motor, namely, the motor drives ball screw to make the junction plate of the laser head move up and down to complete such an action. The stroke at both ends is controlled by a photoelectric switch. Ball screw and linear guide rail are of high quality, ensuring the precision of transmission.

#### 1.2.5 The protective cover

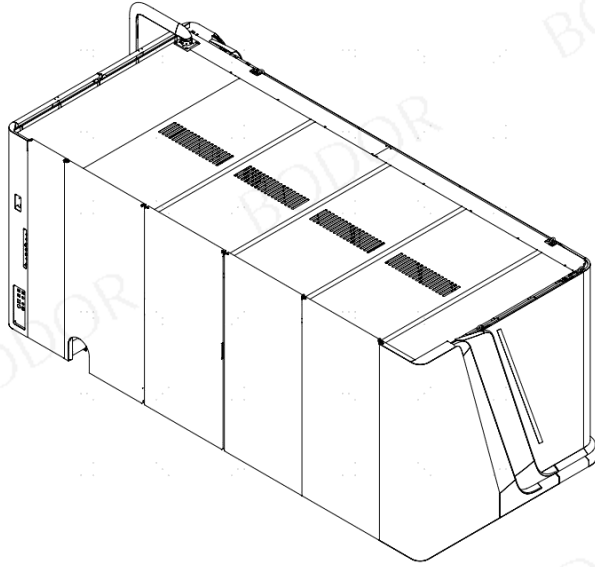

The outer enclosure is divided into front, back, left and right parts, which are welded by sheet metal and profile respectively. Each part is firmly and reliably splicing through bolts. The front and left sheet metal structure is externally attached with tempered glass, which makes the shape more beautiful. The front door adopts electronic control vertical lifting door structure, open and close with one key operation, and respectively equipped with deceleration, stop detection switch, higher safety performance. The display screen adopts touch screen, high sensitivity, both visual sense and good handling. Bolts are used to connect the outer enclosure with the main body of the equipment, so that the whole shipment can be carried out without reassembling at the customer's site. The front cover is provided with a visual window to facilitate the operator to observe the cutting process; Laser protective glass is pasted inside the window, which can effectively prevent the harm of laser to the operator's vision when cutting.

## 1.3 Introduction to Each Functional System

### 1.3.1 Dedusting system

The laser cutting machine is configured with the dust collection system, and the dust collection pipeline in lathe bed body, air duct with a large diameter and high power fan are used to effectively inhale dust generated during laser cutting process, and to collect emissions, ensuring the health of the operator.

### 1.3.2 Air circuit system

The air circuit part of the laser cutting machine is divided into two types, cutting air circuit and working air circuit. The cutting air circuit is used to supply low-pressure oxygen and high-pressure nitrogen for cutting. The working air circuit is



used to supply compressed air for pneumatic unit. All gases should be dry and clean, with high purity and have no oil.

The main function of oxygen is to cut ordinary carbon steel, and that of nitrogen is to cut non-ferrous metals such as stainless steel and alloy steel. The use of different cutting gases depends on different materials.





### 1.3.3 Lubricating system

The centralized lubricating system is used to automatically supply oil for sliding block, ensuring the precision of the transmission system, improving the service life of linear guide rail.

### 1.3.4 Cooling system

The waterway system of the laser cutting machine adopts the dual temperature water-cooling machine. One way is used to cool the laser, and the other is to cool the cutting head.



## II. Equipment Installation and Connection

### 2.1 Inspection and Acceptance after the Arrival of the Equipment.

Inspection and acceptance of goods in the container: Check whether the packaging of the host equipment in the container is damaged before unloading. If there is damage, the recipient should take pictures in the container (Photos should be clear).

Check whether the marks of anti-inversion and anti-collision on the packing cases are abnormal (normally, they are colorless; abnormally, they are red), as shown in the figure below. If those marks are found to be abnormal, the recipient should take pictures in the container (Photos should be clear).

In case of abnormal marks, keep well the packing cases and clear photos of the damaged location. If the mode of transportation is air transport, check and confirm whether the equipment is damaged or not on site. Sign to receive after checking there is no damage. If there is any breakage, please reject it and contact us. If the packing cases of the equipment for sea or land transportation are damaged or the marks of inversion and anti-collision are abnormal, the recipient should take pictures and continue to unpack for check; if the equipment is damaged, the recipient should immediately report to the insurance company specified on the policy and protect the scene. Meanwhile, the recipient needs to contact our customer service staff at the same time so as to determine the solution.





## 2.2 Specification and Requirements for Packaging Removal

Remove the packing tape if the equipment is packed in a wooden case, and remove the wooden board in order from top to bottom so as not to cause damage to the equipment in the case. Do not open with a sharp object if the equipment is wrapped with a protective film to avoid scratches on the surface of the equipment and damages to all kinds of electrical and air pipes. The Company shall not replace the equipment damaged by the customer.

When taking delivery, the optical fiber devices are usually placed in the wooden cases, therefore, carefully unpack the wooden cases, especially, do not to damage fiber cable; in order to better protect the equipment, the packing film on the equipment should not be opened before the location is determined.

## 2.3 Equipment mechanical installation process

I7 series mechanical installation process reference (i7 series on-site adjustment process specification).

## 2.4 Circuit Connection

The machine is composed of multiple parts, and each part should be electrified. Please make sure that the circuit of each part is connected correctly. Incorrect connection may cause damage to the equipment.

### 2.4.1 Connection of Main Power Cord of the Equipment

The main power cord of the equipment is a five-core cable with a three-phase five-wire system. The main power supply can be directly connected to the customer's main switch if the customer's voltage is three-phase 380V. If, however, the voltage is not three-phase 380V, it is necessary to add a complete machine transformer to change its power supply to 380V, and connect the main power cord to the output end of the transformer to supply to the electric control cabinet.

All tubes, wires and other components are ensured to supply power to the whole equipment after connecting, without short circuit in the electric control cabinet.

### 2.4.2 Connection of external equipment and electric control cabinet

- 1) The additional equipment externally carried by the equipment includes complete machine transformer, voltage stabilizer, laser, water chiller, air compressor, fan or smoke purifier, etc.;



- 2) When the customer's power supply input voltage is three-phase 380V, the whole machine power supply is directly connected to the customer's power supply side, without the need to use complete machine transformer.
- 3) When the laser power is  $\geq 2\text{kW}$ , if the equipment is equipped with complete machine transformer or voltage stabilizer, the laser power cord should be connected to the output side of complete machine transformer or voltage stabilizer. If the equipment is not equipped with complete machine transformer or voltage stabilizer, the laser power cord is directly connected to the customer's power supply side.
- 4) The power lines of smoke purifier, water chiller with power  $\geq 2\text{kW}$ , air compressor and other peripherals (except laser) are not controlled by voltage regulator. If the voltage regulator is configured, please connect the power line of the above peripherals (except laser) to the input side of the voltage regulator.  
  
If the equipment is equipped with complete machine transformer, the power cords of all the peripherals mentioned above are connected to the output side of complete machine transformer. If the equipment is not equipped with complete machine transformer, the power cords of all the above peripherals are directly connected to the customer's power supply side.  
  
Note that if the CE equipment is equipped with complete machine transformer and the customer's power supply voltage is three-phase 400V or single-phase 230V, the water chiller configured with CE is directly connected to the customer's power supply side.
- 5) When the input power of the 2kW and 3kW water chiller or the 2kW laser is single-phase 220V, please connect the water cooler power cord or laser power cord to the customer's single-phase 220V on the customer's power supply side.
- 6) When the input power of a water chiller with a power of less than 2kW or a laser with a power of less than 2kW is single-phase 220V, please connect the power cord of the water chiller or the laser power cord to the aviation socket of the electric control cabinet.
- 7) The power cord of the i series fan is directly plugged into the aviation socket of the electric control cabinet.



### 2.4.3 Safety Precautions for Electricity Use

Make sure that voltage of all equipment meets the requirements of the machine, and that the power cord and the circuit breaker are securely connected so as to avoid damage to the equipment caused by lack phase.

The shell of each equipment must be grounded to avoid damage to electrical components of the equipment caused by static, and to avoid injury to the operator caused by circuit failure and electric leakage.

When replacing electrical components, cut off power, and wait for a period of time before operation. Live-wire work is strictly prohibited. Regularly remove dust on the circuit breaker, transformer and wiring board to prevent current from breaking through dust, which may cause damage to the equipment.

Turn off the industrial control computer first and then turn off the main power supply after the work is completed.

### 2.5 Connection to Gas Circuit

Two air pipes extend from the lathe bed. One is used to connect nitrogen (compressed air or nitrogen is used while cutting), and the other is used to connect oxygen. Connect the nitrogen pipe to the nitrogen supply unit through the nitrogen gauge, and connect the oxygen pipe to the oxygen supply unit through the oxygen gauge.

Refer to the schematic diagram of gas circuit in the standard file for details.

Refer to the requirements in the running materials for gas specification.

Attention points of gas circuit installation

- 1) Gas purity may affect the speed and effect of cutting, and high-purity gas may bring high speed and better effect.
- 2) For different countries or regions have different standards, our standard configuration of nitrogen and oxygen gauges may be unable to connect to your gas supply device; under such situations, please purchase nitrogen and oxygen gauges separately in the local market.
- 3) The temperature of the supplied gas should be not over 50°C;
- 4) In principle, it is recommended to keep in contact with gas suppliers in the issues of gas supply;
- 5) If gas source is farther away, it is strictly prohibited to lay down gas pipes and cable in the same pipeline, and gas pipes are separately connected to the joint of the machine tool;





- 6) Installation of gas pipes requires professional installation personnel, and the initial installation requires air exhaust. Make sure that the pipes are clean before connection to the machine tool.

## 2.6 Connection to Waterway

The water cooling machine outputs two waterways, high-pressure waterway and low-pressure waterway. The high-pressure water flows to the optical fiber plug and the cutting head. Pay attention to the direction of water inlet and outlet, make water first flow through the optical fiber plug and then through the laser cutting head. Low-pressure water flows to the optical fiber devices. Due to different brand of optical fiber device, the type of waterway connection may be different, and the specification of joint pipe also may be different. Please recognize the flow direction and mark number of waterway, and correctly connect to the waterway with water pipes which are attached to the machine.

Refer to the waterway schematic diagram in the standard files for details.

Attention points of waterway installation

- 1) Non-mineral purified water, distilled water or deionized water is added to the water-cooling machine, and it is forbidden to add corrosive liquids or water with impurities.
- 2) When adding water, avoid unnecessary contact with water (for example, touch water by hand). All auxiliary equipment such as pumps and hoses should be used only for this water cooling machine.
- 3) Before turning on the water-cooling machine, check its water level, and it is strictly prohibited to turn on the water-cooling machine if there is no water or water level is too low, in order to avoid damage to the water-cooling machine. It is strictly prohibited to squeeze and tread on inlet or outlet pipes of the water-cooling machine in order to keep the waterway unimpeded.
- 4) At a temperature of below 0°C, in case of long-time downtime, discharge cooling water from the water-cooled machine, laser and water pipes in order to prevent cooling water from freezing due to low temperature, which may cause damage to the equipment and pipeline.
- 5) It is recommended to completely replace water in the water-cooling machine every two to three months.



## III. Equipment Startup and Debugging

### Warning

After the acceptance of the machine, the user must remove the packing film, and remove anti-rust oil on the surface of guide rail and the rack surface with pure cotton cloth which had been dipped in kerosene, after that, the machine can work normally.

Note: Before the machine is electrified, please check and confirm that connection to the power cord of the equipment meets the requirements, wiring is firm, make sure there is no short circuit in the electric control cabinet, the overall equipment is well installed, and with no foreign objects or no barriers in the direction of each motion axis. After checking, it is permitted to start up the machine for power supply.

### 3.1 Start-up Process

- 1) Open the plastic case switch on the door of the electric control cabinet to power on the device, and insert the handle driver and keyboard and mouse receiver into the USB interface.
- 2) Turn on the control loop switch, and then turn on the switch button of the industrial personal computer (IPC) to start the computer, next, turn on the driver switch to make the servo driver electrified, and click Bodor Pro to start the software. The laser and water chiller of i series 2kW and above power equipment need external connection, and the switch of laser and water cooler is not included in the electric control cabinet.
- 3) Rotate to the right to turn on the emergency stop button on the side of the monitor.

### 3.2 Inspection of Waterways

Turn on the external power switch of the water chiller, and then turn on the switch knob of the water-cooled machine, (due to different model of the water-cooling machine, after turning on the knob, you may need to click the “Start” button on the panel again.) At this time, the water-cooling machine starts to run, check each interface of the entire waterways. If water leakage is found, immediately turn off the water cooler, and then repair the place where there is water leakage. After repair, retest to ensure there is no water leakage.

### 3.3 Inspection of Gas Circuit

First of all, make sure that there is gas in your gas supply device, and check each gas circuit and interface to see if they are



connected. Turn on the switch of each gas supply device, and turn on the switch on the oxygen gauge and the nitrogen gauge respectively. It is recommended to rotate the switch of the oxygen gauge to 0.3-1.0Mpa and that of the nitrogen gauge to 1.0-2.5Mpa, if the sound of air leakage is heard, search for its position, and solve the problem of air leakage.

After ensuring that there is no air leakage, click the N2 or O2 button in the operation software to confirm whether the air is out, and then click the N2 or O2 button to confirm whether the air is off. If there is any abnormality, it needs to be solved.

### **3.4 Motion unit test**

Open the software (after opening the software, the prompt of returning to the original point will pop up, please click the "Close" button). Find out the software movement control button, check if the movement mechanism (X, Y, Z axis, etc.) can normally run at a low speed, and move to the limit switch to test if all limit switches are valid.(If the machine has additional functions, make the corresponding tests)

If there is an alarm in the z-axis direction at the top of the software interface, it needs to be solved through calibration. If there is any other alarm, please check the alarm content and find the possible problem. If it cannot be solved, please contact us. When all the movements become normal, click "Go Home" in the "Processing" menu bar tabs, and return to the original point; or restart the software, and click on "All Axes" when the prompt of returning to the original point pop up.

### **3.5 Test of Light Emission**

According to the power-on procedure on the laser source, turn on the laser control, click the "Burst" button to test the emission of laser light, and make sure that before testing the water-cooling machine is turned on , and oxygen and nitrogen can be normally blew off.

In general, turn on the water-cooling machine, and then open the optical fiber device. Namely, when the water-cooling machine and the fiber optic device are on standby, turn on the switch knob of the water-cooling machine, and then turn on the key switch and switch button of the optical fiber device when water supply becomes normal.

However, attention should be paid to the following points:

- 1) When water temperature is lower, after it rises to 20°C, open the optical fiber device.
- 2) Due to different models of the water cooling machine, after turning on the knob, click the "Start" button on the panel



again to start the water-cooling machine.

3) Due to different power, brand and model of the optical fiber device, the operating method is a bit different.

For example, there is no button on the 500W-1,000W G optical fiber device, and its key switch and switch button are integrated into the operational software.

For example, for the high-power optical fiber device, open the key switch of the optical fiber device or turn on the handle switch, and then make the dehumidification device of the optical fiber device run for ten minutes, after that, turn on the water-cooling machine and make its running temperature up to a certain degree, and then make the optical fiber device emit light.

For example, for the Bodor Power fiber optic devices with power of less than 1000W, turn on the key switch of the optical fiber device, after waiting for a few seconds, click “START” to output red light as instructed; after that, click on the “Shutter” button in the software, and then click the " Burst " button, there will be laser under the nozzle.

For example, turn on the key switch of some fiber-optic devices (or rotate the key switch to “REM” location), click “START” (or don’t click it), and then click “Shutter” in the software, and then click the “Aiming” and “Laser” buttons.

Due to multiple brands and models of the fiber optic device, other detailed operations are not listed any more, if you have any questions, please contact us.

### 3.6 Turning off the Machine Tool

First of all, exit from the software. Click the computer shutdown button , after the computer is completely shut down, then turn off the main switch of the power supply.

### 3.7 Summary

This Chapter introduces the preparatory work before starting work. There are no strict requirements for the boot sequence of various parts, so it is recommended that the boot sequence is as follows: Host machine and operational software → Gas supply device → Water-cooling machine→ Optical fiber device

Tips Shutdown sequence

1) After completing the cutting process, respectively click the N2 or O2 button to discharge the gas in each trachea and



close the gas supply device.

- 2) Use the adhesive tape under the nozzle of the cutting head to prevent dust from entering the cutting head.
- 3) Move the X-axis and Y-axis to the middle of the machine tool in order to avoid the deformation of transmission shaft caused by self-weight, affecting the cutting precision.
- 4) Turn off the switch on the laser source to disconnect power supply.
- 5) Turn off the switch on the water-cooling machine to disconnect power supply.
- 6) Turn off the control software, and shut down the host computer.
- 7) Make an inspection tour of the surrounding environment of the machine tool to check whether there is a tinder or high-temperature object, so as to avoid a fire and eliminate potential safety hazards.

#### **Special instructions:**

**1 Due to the different versions of the system, the operation will be different. The detailed operation will not be repeated here. If you are unclear, please refer to the system operation manual or contact our company in time.**

**2 When selecting our air compressor (adapted to 12kW and above laser cutting machine), the operation should be in the following order:**

**Start-up sequence: turn on the refrigerated dryer first, and then turn on the air compressor;**

**Shutdown sequence: turn off the air compressor first, then turn off the refrigerated dryer.**

**Disclaimer: Failure to follow the above sequence may cause irreversible pollution to the machine tool pipeline, air valve and cutting head. The resulting losses and various costs are borne by the customer and are not within the scope of our company's responsibility.**



# Equipment Operating Instruction

## I. Basic Knowledge of Laser Machining

### 1.1 Laser Machining Principle

Laser cutting is an advanced and relatively widely-applied cutting technology in material machining. It is a machining method, in which laser beams with high-energy density are used as the “Cutting Tool” to make thermal cutting of materials. The laser cutting technology can be used to cut all kinds of metal, non-metal plates and composite materials, and widely applied in all fields.

Laser cutting means that the focused laser beam is used to irradiate workpieces, so that the irradiated materials can rapidly melt, evaporate, ablate or reach the ignition point; at the same time, with the aid of high-speed airflow with the same axis as beam light, wipe off molten substances to realize workpiece cutting. Laser cutting is one of the thermal cutting methods.

### 1.2 Main Methods of Laser Machining

#### 1) Laser fusion cutting

Laser fusion cutting means that metal materials are molten through laser heating, non-oxidizing gas is injected through the nozzle with the same axis a beam light ( $N_2$ , Air, etc.), and then liquid metal is eliminated by means of great pressure of gas, ultimately, kerf is formed.

Laser fusion cutting is mainly used to cut non-oxidizing materials or active metals, such as stainless steel, titanium, aluminum, alloys, etc.

#### 2) Laser oxygen cutting.

The principle of laser oxygen cutting is similar to that of oxyacetylene cutting, namely, laser is used as the preheating source, and oxygen and other active gases as the cutting gas. On the one hand, the emitted gas has an oxidation reaction with the metal, releasing a mass of oxidation heat; on the other hand, the molten oxide and the melt are blown out of the reaction area, and form a kerf in the metal.

Laser oxygen cutting is mainly used for carbon steel and other easily-oxidized metal materials, which is also used for



machining the materials such as stainless steel. However, the cross section is dark and rough, and its cost is lower than that of inert gas cutting.

### Tips

**The i series products are the equipment for cutting metal materials with a laser. The i series products shall not be used for cutting non-metals (e.g. glass, acrylic materials, wood, etc.)!**

## 1.3 Focal Position

Relative to the surface of machined materials, after laser beam focusing, the place where the focal point is located is called the focal position. The focal position determines beam diameter, power density and kerf shape on the surface of the workpiece. In the process of laser cutting, the relative position of beam focus and cutting board surface has a great influence on the quality of cutting, so it is very important to correctly adjust the focal position. This laser cutting machine is configured with high-precision automatic following control device. When the height of the plate is changed, the numerical control system can automatically adjust the distance between the nozzle and the plate so as to maintain constant height from the nozzle to the plate surface, to ensure the stability of the focal position.

The focusing mechanism of focus lens is to pull the focusing box with precision screws so as to realize focusing, with good self-locking performance and fine focusing function.

The following table shows the relationship of focal position, the cutting materials and cross section.

Name and Focal Position	Cutting Materials and Cross-section Characteristics
Zero focus: The laser focus is on the plate surface.	It is used for thin plate cutting. At this point, the maximum capability density, the minimum beam diameter and the narrowest kerf can be obtained on the material surface.
Positive focus: the laser focus is above the plate surface.	It is used for laser oxygen cutting. The focus is on the surface, the focal position is enlarged, and the kerf is increased accordingly.
Negative focus: the laser focus is below the plate surface.	It is used for laser fusion cutting. The focus is inside the material, the focal position is reduced, and the kerf is increased accordingly.



## 1.4 Nozzle

### 1.4.1 Functions of the Nozzle

Due to different nozzle design, the flow of air stream is different, which directly affects the quality of cutting. The main functions of the nozzle include:

- 1) Prevent sundries during cutting and melting from bouncing upwards the cutting head, which may damage the lens.
- 2) The nozzle can make the jetted gas more concentrated, control the area and size of gas diffusion, thus making the quality of cutting better.

### 1.4.2 Influence of the Nozzle on the Quality of Cutting and Selection of the Nozzle

1) Relationship of the nozzle and the quality of cutting: The quality of cutting can be affected by the deformation of the nozzle or the residue on the nozzle. Therefore, the nozzle should be carefully placed and should not be collided. Residue on the nozzle should be timely cleaned. High precision is required during manufacturing the nozzle, if the cutting quality is poor because of the poor quality of nozzle, please timely replace the nozzle.

2) Selection of the nozzle.

In general, when the nozzle diameter is small, the airflow speed is fast, the nozzle has a strong ability to remove the molten material, suitable for cutting the thin plate, and the fine cutting surface can be obtained; when the nozzle diameter is large, the airflow speed is slow, the nozzle has a poor ability to remove the molten material, suitable for slowly cutting the thick plate. If the nozzle with a large aperture is used to rapidly cut the thin plate, the residue generated may splash up, causing damage to the protective glasses.

In addition, the nozzle is also divided into two types, i.e. a composite type and a single-layer type (see the figure below). Generally speaking, the composite nozzle is used to cut carbon steel, and the single-layer nozzle is used to cut stainless steel.



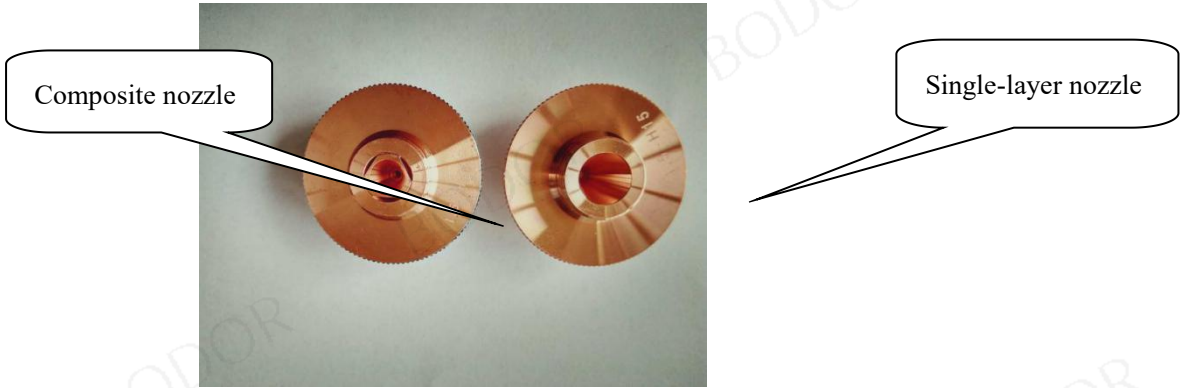

Material Specification	Material Thickness	Nozzle Type	Nozzle Specification
Cs	Less than 3mm	Composite nozzle	Φ1.0
	3--12mm		Φ1.5
	than 12mm		Φ2.0 或 Φ2.0 以上
Ss	1	Single-layer nozzle	Φ1.0
	2--3		Φ1.5
	3--5		Φ2.0
	5mm 以上		Φ3.0 或 Φ3.0 以上

**Subject to materials and processing gas, data in the table will be different. As a result, the data herein is for reference only!**

**We recommend that you purchase our special nozzles because the nozzles of different manufacturers have a greater impact on the cutting effect.**

### 1.5 Dimming ( Laser coaxial)

Steps for adjusting the laser light to pass through the nozzle center are as follows:

- 1) Open the software, move the beam and the laser cutting head to the appropriate position.
- 2) Evenly apply the transparent adhesive tape to the end face of the nozzle (see the figure below).
- 3) Set in the appropriate power (80-100W) in the software, click on the “Laser” (or “Laser” button on the handle), the “☉” icon may appear on the tape, take down the transparent adhesive tape, and be careful not to rotate its relative



position. If no light spot ejected is in the nozzle center, it is necessary to adjust the knob on the upper of the cutting head so as to make light spots in the nozzle center. Repeat the above action until the aperture on the transparent adhesive tape ejected by the laser coincides with the nozzle center.

When the nozzle center is not coaxial with the laser center, the effects on the quality of cutting, are as follows:

- 1) Affecting the cutting cross-section. When the cutting gas is ejected, uneven gas volume may cause inconsistent quality around the cutting cross section, and even abnormal cutting.
- 2) Affecting the quality of sharp angles. When cutting the workpiece with a sharp or a smaller angle, it is easy to produce partial super-perfusion. When cutting the thick plate, sharp corners cannot be cut.
- 3) If perforation is unstable, perforation of the thick plate may cause super-perfusion, and penetration time is not easy to master. The concentricity of the nozzle center and the laser is one of the important factors to decide the quality of cutting, especially, the thicker the workpiece is, the greater the effect. Therefore, it is necessary to adjust the concentricity of the nozzle center and the laser, thus getting a better cutting cross-section.

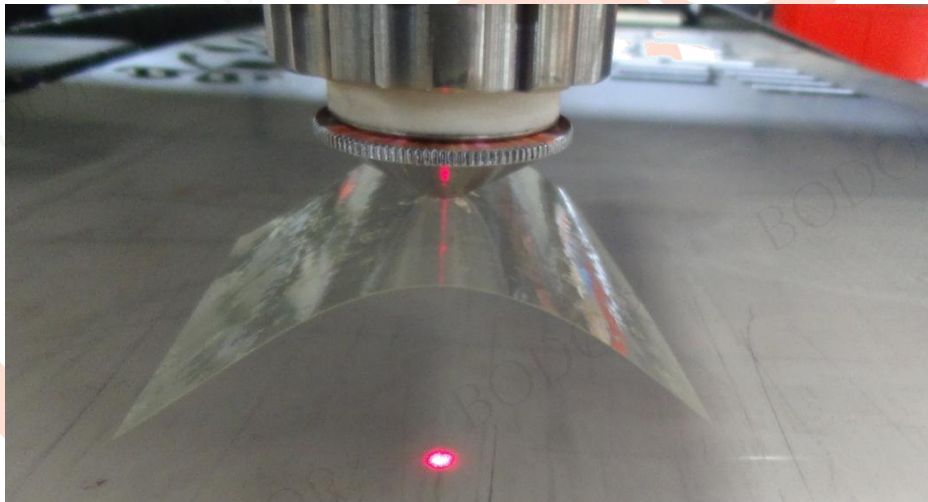

(Sketch of the dimming method)

**Warning: it must be operated by a single person to prevent accidents at the time of machining the same axis. It is strictly prohibited to operate by two or more people at the same time!**

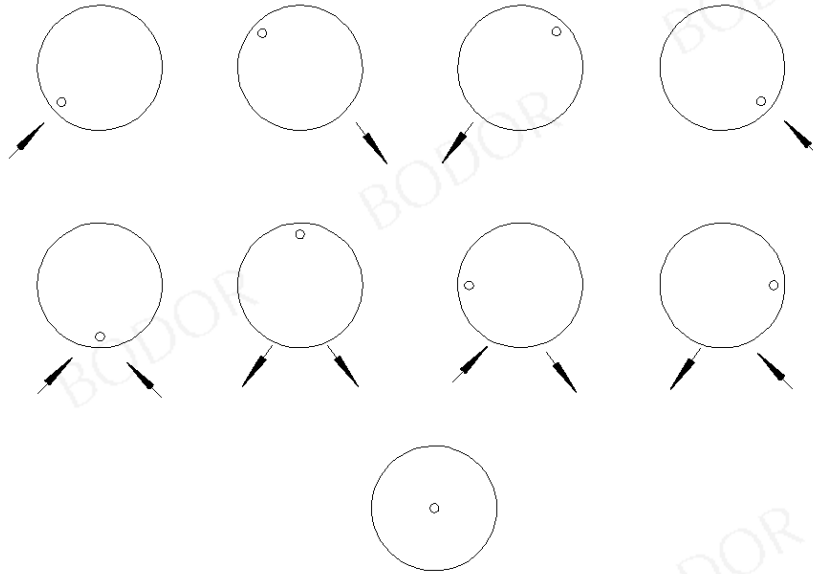

(Sketch of the dimming method)

## 1.6 Factors Affecting the Cutting Technology

### 1.6.1 Impact on Cutting Plates

Different types of plates with different quality will have a great influence on the quality of laser cutting. The following conditions must be met when using plates in order to ensure normal laser processing:

- 1) Conventional laser cutting uses Q235A, Q235B, 201 and 304 as main materials, and the plates shall comply with *Dimension, Shape, Weight and Tolerance for Cold-rolled Steel Plates and Sheets (GB 708-1988)*, and *Cold-Rolled Stainless Steel Plate, Sheet and Strip (GBT 3280-2015)*, coupling with a *Product Quality Certificate*. The products made by large-scale steel plants, for example, China Baowu Steel Group Corporation Limited., SD Steel Group, Anshan Iron and Steel Group Corporation, and China Shougang Group are required. If the products made by local small steel plants are used, it will increase the difficulty of debugging and reduce the cutting quality.
- 2) The plate surface needs to be smooth without scratches, distortions and other surface defects; the rusted area (single side) shall be evenly distributed and less than 15% of the single side area to see rust color to become lighter (that is, the rust is floating on the surface), failing which it is not suitable for laser cutting plates; the scale area should be uniformly distributed and less than 15% of the single-sided area, failing which it is not suitable for laser cutting plates.



### 1.6.2 Cutting Height

As shown in the figure below, if the distance between the nozzle and the workpiece is too short, it may cause the collision of the plate and the nozzle; if the distance is too long, it may cause gas diffusion, causing more residues on the cutting bottom.

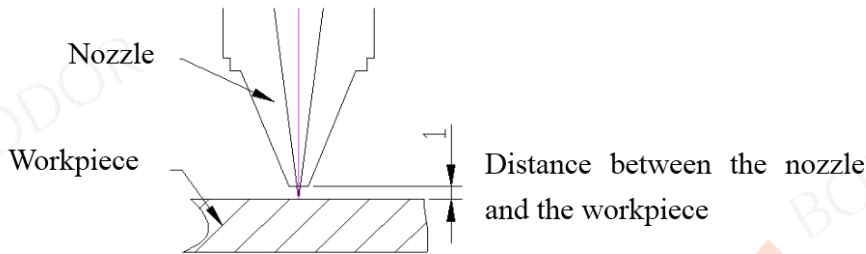

Sketch of the distance between the nozzle and the workpiece

The distance between the nozzle and the workpiece can be set at the “Technology” interface, and the recommended distance is between 0.5-1.5mm.

### 1.6.3 Cutting Speed

The speed of feeding can be judged from the cutting spark. Under the condition of normal cutting, the spark is diffused from top to bottom, and when the spark is tilted, the speed of feeding is too fast; if the spark is not diffused but condensed, the speed of feeding is too slow. The following figure shows the appropriate cutting speed, the cutting surface shows a smooth line, and no slag comes from the lower part.

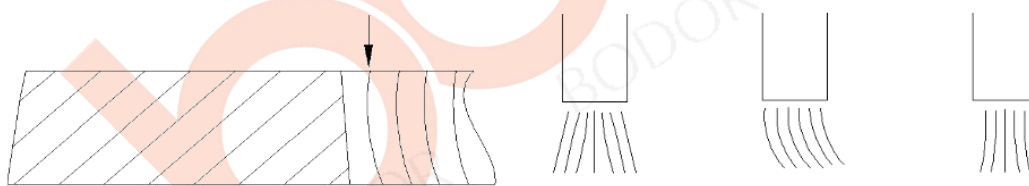

The spark is diffused from top to bottom

The spark is tilting, and the speed of feeding is too fast

The spark is not diffused, and the speed of feeding is too slow

Sketch of cutting cross section and cutting spark effect

### 1.6.4 Plate type and quality

The different types and quality of the plates have a serious impact on the laser cutting effect and efficiency. The wrong selection of the cutting process for different types of plates can cause abnormal cutting and even damage the optical



components such as the laser head.







<b>Carbon content</b>	<b>Achieved cutting quality</b>
$C \leq 0.25\%$	Suitable for laser cutting and can guarantee the cutting effect
$C \leq 0.60\%$	Reduce cutting quality
$C > 0.6\%$	Not suitable for laser cutting
<b>Silicon content</b>	<b>Achieved cutting quality</b>
$Si \leq 0.04\%$	Suitable for laser cutting and can guarantee the cutting effect
$Si \leq 0.25\%$	Can slightly reduce the cutting quality
$Si > 0.25\%$	Not suitable for laser cutting, the cutting effect is reduced
<b>Other trace element content</b>	<b>Achieved cutting quality</b>
$Cr > 1\%$	Not suitable for laser cutting, the cutting effect is reduced
$Mn > 0.5\%$	Not suitable for laser cutting, the cutting effect is reduced
$S > 0.04\%$	Not suitable for laser cutting, the cutting effect is reduced

In case of poor quality of cutting, it is recommended to carry out a general inspection first, of which the content and sequence are as follows:



- 1) Cutting height (it is recommended that the actual cutting height is between 0.5 and 1.5mm): If the actual cutting height is not accurate, the calibration should be carried out.
- 2) Nozzle: Check the type and size of the nozzle to see if it is used correctly. If it is correct, check whether the nozzle is damaged, and the roundness is normal.
- 3) It is recommended to conduct an optical center inspection of the nozzle with a diameter of 1.0, and the focus should be between -1 to 1 while inspecting the optical center. In this way, small light points are easy to be observed.
- 4) Protective lens: Check whether the lens is clean, and confirm there are no water, no oil and no slag on the lens.  
Sometimes the protective lens may be fogged due to weather or too cold auxiliary gas.
- 5) Check whether the focus is set correctly.
- 6) Modify the cutting parameters.



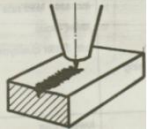

After checking the above six items, if no problems, modify the parameters according to the phenomenon.

Structural steel: Cutting with O <sub>2</sub>		
Defects	Possible Cause	Solutions
<p>There is no burr, and the drawn wire is consistent.</p> 	<p>Power is proper</p> <p>The cutting speed is proper</p>	
<p>The drawn wire at the bottom has a large deflection and the bottom kerf is wider.</p> 	<p>The cutting speed is too high</p> <p>Cutting power is too low</p> <p>Air pressure is too low</p> <p>The focus is too high</p>	<p>Reduce the cutting speed</p> <p>Increase cutting power</p> <p>Increase air pressure</p> <p>Lower the focus</p>
<p>Burrs at the bottom surface are similar to slag, and like droplet and easy to remove.</p> 	<p>The cutting speed is too high</p> <p>Air pressure is too low</p> <p>The focus is too high</p>	<p>Reduce the cutting speed</p> <p>Increase air pressure</p> <p>Lower the focus</p>
<p>Connected metal burrs can be removed as a whole piece.</p> 	<p>The focus is too high</p>	<p>Lower the focus</p>
<p>Metal burrs at the bottom surface are difficult to remove.</p> 	<p>The cutting speed is too high</p> <p>Air pressure is too low</p> <p>Gas is not pure</p> <p>The focus is too high</p>	<p>Reduce the cutting speed</p> <p>Increase air pressure</p> <p>Use purer gas</p> <p>Lower the focus</p>
<p>Burrs are only on one side.</p> 	<p>Coaxial laser is not correct.</p> <p>The opening of the nozzle has defects.</p>	<p>Align coaxial laser</p> <p>Replace the nozzle</p>



<p>Materials are discharged from above.</p> 	<p>Power is too low</p> <p>The cutting speed is too high</p>	<p>Increase the power</p> <p>Reduce the cutting speed</p>
<p>The surface of cutting is not precise.</p> 	<p>Air pressure is too high</p> <p>The nozzle is damaged.</p> <p>The nozzle diameter is too large.</p>	<p>Reduce air pressure</p> <p>Replace the nozzle</p> <p>Install an appropriate nozzle</p>

**Stainless steel: Cutting with N<sub>2</sub> high pressure**

Defects	Possible Cause	Solutions
<p>Regular small droplet-like burrs are produced.</p> 	<p>The focus is too low</p> <p>The cutting speed is too high</p>	<p>Raise the focus</p> <p>Reduce the cutting speed</p>
<p>Irregular long filamentous burrs are produced on both sides, and the surface of large plate discolors.</p> 	<p>The cutting speed is too low</p> <p>The focus is too high</p> <p>Air pressure is too low</p> <p>The material is too hot</p>	<p>Increase the cutting speed</p> <p>Lower the focus</p> <p>Increase air pressure</p> <p>Cool the material</p>
<p>Irregular long burrs are produced on the cutting edge.</p> 	<p>Coaxial laser is not correct.</p> <p>The focus is too high</p> <p>Air pressure is too low</p> <p>The cutting speed is too low</p>	<p>Align coaxial Laser</p> <p>Lower the focus</p> <p>Increase air pressure</p> <p>Increase the cutting speed</p>
<p>The cutting edge becomes yellow.</p>	<p>Nitrogen contains oxygen impurities.</p>	<p>Use high-quality nitrogen</p>
<p>Light beam is diffused at the beginning.</p>	<p>The acceleration is too high</p> <p>The focus is too low</p> <p>The molten material cannot be discharged</p>	<p>Reduce the acceleration</p> <p>Raise the focus</p> <p>Pass through a circular hole</p>

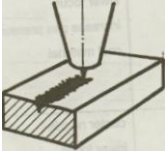

The kerf is rough.	The nozzle is damaged. The lens is dirty	Replace the nozzle Clean the lens, and replace it if necessary.
The material is discharged from above. 	The power is too low The cutting speed is too fast Air pressure is too high	Increase the power Reduce the cutting speed Reduce air pressure

### 1.6.5 Cutting effect of corresponding plate in each power section

Power		Carbon steel (Q235A)			Stainless steel		
		Thickness mm					
4KW	Thickness mm	1	10	20	1	3	12
	Effect						
6KW	Thickness mm	1	14	20	1	12	20
	Effect						
8KW	Thickness mm	1	16	25	1	14	25
	Effect						
10KW	Thickness mm	1	6	10	1	4	8
	Effect						
	Thickness mm	16	20	30	14	20	25
	Effect						





12KW	Thickness mm	1	8	14	1	6	12
	Effect		8mmCS 	14mmCS 			12mmSS 
	Thickness mm	18	20	30	16	20	30
	Effect						
15KW	Thickness mm	1	8	14	1	6	14
	Effect						
	Thickness mm	20	30	40	20	30	40
	Effect						
20KW	Thickness mm	1	10	16	1	10	16
	Effect						
	Thickness mm	20	30	40	20	30	40
	Effect						

Power		Aluminium alloy		Brass	
4KW	Thickness mm	1	12	1	8



	Effect				
6KW	Thickness mm	1	20	1	12
	Effect				
8KW	Thickness mm	1	25	1	16
	Effect				
10KW	Thickness mm	1	6	1	6
	Effect				
	Thickness mm	20	30	10	16
	Effect				
12KW	Thickness mm	1	8	1	6
	Effect				
	Thickness mm	20	30	10	18
	Effect				
15KW	Thickness mm	1	10	1	6
	Effect				
	Thickness mm	20	30	14	18



	Effect				
20KW	Thickness mm	1	14	1	10
	Effect				
	Thickness mm	20	30	14	18
	Effect				

**Note: this parameter is for reference only, which cannot be used as the basis for acceptance or quality traceability because different conditions on the site (plate quality, gas quality, etc.) influence a lot. It is the responsibility of Bodor Power for the final explanation!**

- 1) The cutting effect is subject to different fiber optics, material quality, gas, optical lenses, cutting graphics, etc., in which case it is necessary to be adjusted according to the site conditions; (the plate model used for this parameter: Q235 for carbon steel, 201 for stainless steel, 5# for aluminum, H6 of copper, and the plate thickness of the theoretical thickness, but the actual thickness is slightly smaller than 0.2 ~ 0.5mm).**
- 2) The cutting accuracy is affected by the quality of different material types and material surface, and installation status of machine tool. As a result, we recommend that when cutting precision workpieces, the cutting speed is reduced with the recommended speed below 12m/min.**
- 3) Requirements for cutting gas: nitrogen (purity  $\geq 99.99\%$ ), oxygen (purity  $\geq 99.9\%$ ) for cutting.**
- 4) At the time of cutting highly reflective materials such as copper and aluminum, attentions should be paid to adjust the process, during which the limit thickness is not recommended for continuous and long-term processing. Bodor Laser can cut highly reflective materials under normal cutting conditions; but we do not recommend long-term cutting.**

**Tips:**

- 1) We recommend that the layout spacing is  $\geq 0.8$  time the thickness of the plate to avoid thermal deformation and poor cutting.**
- 2) The intensive cutting within a small range of this processing method will cause damage to the lathe bed and the countertop, which is not covered by the product warranty.**
- 3) In the event of long-stroke continuous cutting (single cutting straight line  $> 2m$ ), thermal deformation of the plate**



**will affect the final straightness, which is not covered by the product warranty.**





## **II. Application of External Functions of the Equipment**

### **2.1 USB Interface**

The production system is not directly connected to the machine tool, but data can be transmitted via the USB interface, and the wireless key mouse receiver is also inserted into the USB interface to realize wireless operation.

### **2.2 Return to Zero**

After the machine tool is electrified, in order to make the equipment safely move within the stroke, carry out return-to-zero operation first, open the software, and press the return-to-zero button on the software interface to make the X, Y, Z axes return to zero automatically.

### **2.3 Draught Fan Startup**

The draught fan starts automatically with the cutting process. After the cutting, the draught fan closes automatically after a certain time delay, usually without manual control. Note that all axes return to zero before cutting.

### **2.4 Automatic Focusing**

laser heads come with the function of automatic focusing, open the software, Click the layer on the left side of the software, in the pop-up setting window, you can set the desired focus height, When cutting, it will automatically move to the set focus position and start cutting.



### III. Machining Process

With respect to specific processing procedures, please refer to the *Instructions on Operating System* in the accompanying document.

**Disclaimer:** Please read the *Instructions on Operating System* before operating the equipment. Any operation other than those regulated herein shall be considered as non-compliant use; any losses caused thereby, especially property damage, personal injury, production losses and other risks, shall be solely borne by the user, for which Bodor shall not be liable.

**Note:** the operator can find the best parameters (speed, air pressure, focal length, etc.) through multiple tests, thus improving quality and work efficiency of workpieces. We recommend that the user save the best parameters and record the focal data at the time of naming, which can be called directly when processing the same material next time.



# Instructions of Equipment

## Maintenance and Repair

Professional maintenance is the prerequisite for maintaining machine tools; it can effectively avoid running faults and the consequences incurred.

 <b style="font-size: 1.2em;">DANGER</b>	<p>Conducting the maintenance work when the machine tool is connected, there may be life dangerous!</p> <ol style="list-style-type: none"> <li>1) If no other clear instructions, turn off and lock the main switch, and pull out the key.</li> <li>2) Strictly abide by the safety regulations.</li> </ol>
---	---

### Before putting into operation

Before the machine tool is put into operation, the machine must be lubricated carefully according to the lubrication chart. For export products by sea or other means of transport, it is necessary to clean up 204-1 replacing-type anti-rust oil before the equipment is put into operation, and check the lubrication condition of the entire machine tool at the same time. When necessary, completely remove all lubricating points and the concretionary lubricants in the pipeline.

### Precautions for cleaning operation

Regularly clean the equipment.

Sweep away big dirt or clean it with an industrial vacuum cleaner.

### Precautions for lubrication

The lubrication of the machine tool shall be carried out according to the lubrication chart and maintenance instructions. In addition, attention should be paid to the following points:

- 1) The inlet and outlet should be kept clean, and opening time not exceed the time required.
- 2) Waste oil can be eliminated only in the state of equipment warm-up.
- 3) Only wiping rag without fiber flock and diluent lubricant for guide rail can be used to clean the lubrication part; it is not allowed to use waste wool and benzene-contained liquid for cleaning.
- 4) Synthetic lubricants shall not be mixed with mineral oils or synthetic lubricants produced by other manufacturers (even



homogeneous synthetic lubricants).

5) Properly dispose waste oil.

#### Qualifications of maintenance personnel

All maintenance work should be carried out only by personnel who have received maintenance training and have relevant knowledge.

In addition to the above qualifications, specific maintenance work (e.g. in the high-frequency generator area) also requires vocational training or further study in the field of electronic technology.

Furthermore, professionals are required to be authorized to engage in electronic technical work for this equipment ( Refer to the regulations of VBG4 for authorizing special operation electricians). Besides, the existing regulations of each country are also applicable.





## I. Maintenance Overview

### 1.1 List of Main Maintenance

8h	Removal of slags and dust on the X,Y-axis dustproof cloth	Check and clean up dust and slag on the X,Y-axis dustproof cloth.
8h	Slags and dust collection containers-scrap vehicle	Check and clean up slags and dust collection containers - scrap vehicle.
8h	Removal of slags and dust on the X-axis protection plate	Clean up slags and dust on the X-axis protection plate.
8h	Clean the sheet metal appearance of the device	Clean up dirt dirt grease
40h	Inspection of the pneumatic components and pipelines of the pneumatic system	Check the pneumatic components, pipelines, etc of the pneumatic system
40h	Inspection of the gas circuit components and pipeline of the gas source	Check gas circuit components, pipeline, etc. of the gas source
40h	Inspection of the circulating water pipeline	Check the circulating water pipeline, etc.
40h	Dust cleaning and guide rail lubrication of parts in the head shell	Clean the dust of the parts in the head shell, and oil the surface of the guide rail
40h	Clean the sheet metal inside the device	Clean up dirt dirt grease
100h	Refueling and cleaning of the self-lubricating container	Check whether to timely refuel the self-lubricating container, and check and clean up oil circuit.
100h	Inspection and cleaning of slag on the countertop blade.	Clean the slag on the countertop blade. Replace if necessary.
500h	Middle square pipe and hopper slag and dust cleaning	Check the air inlet and hopper slag and dust and clean it
500h	Cleaning of filter screen of the water-cooling machine	Clean up filter screen of the water-cooling machine.



500h	Z axis rack, gear cleaning, grease, Z axis guide rail inspection	Z-axis rack and gear cleaning, grease, check Z-axis guide rail surface wear, if necessary, replace the lubricating oil box.
500h	X, Y axis guide rail, X, Y axis gear rack cleaning and oiling	Check and clean X, Y axis guide rail, X, Y axis gear rack clean and oil.
500h	Safety grating cleaning	Clean the safety grating surface
1000h	Oil change and cleaning of the self-lubricating container	Rinse thoroughly the self-lubricating container, and replace lubricant.
1000h	Clean the oil filter element	Clean the oil filter of the automatic lubrication system.
2000h	Replace the filter element	Replace the filter element of the cutting air system.
5000h	Adjustment of X,Y axis gear rack back lash	Check and verify the verticality of X, Y-axis, and respectively check, verify and adjust X,Y-axis gear rack back lash.
Every six months	Cooling device	Replace cooling water (clean circulating water).
6000h	Filter element replacement	Clean and replace the filter element of the intake filtration device

Single-shift Running :

8 running hours	Every day
40 running hours	Once a week
100 running hours	Every fourteen days
500 running hours	Every quarter
1,000 running hours	Every half a year
2,000 running hours	Every year
5,000 running hours	Every two years and a half
15,000 running hours	Every seven and a half years



Every five months	Irrelevant to running hours and six months after
Every two years	Irrelevant to running hours and two years after
Every three years	Irrelevant to running hours and three years after





**1.2 Lubrication**

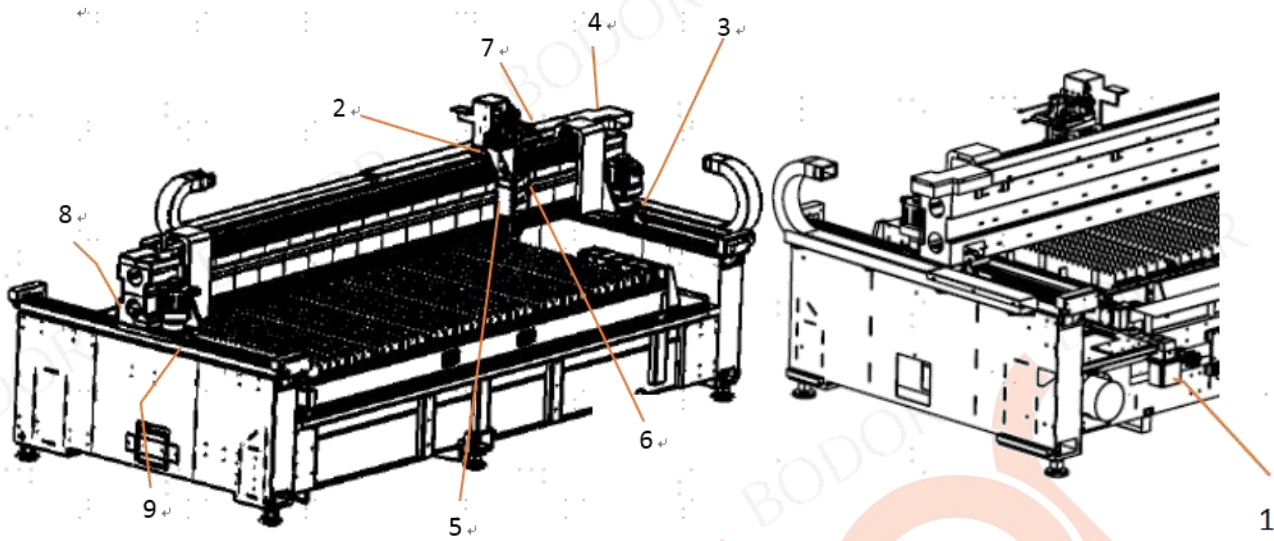

- ① Automatic lubrication pump    ② X axis left rail slide block 1    ③ X axis left rail slide block 2
- ④ Y axis lower side guide slide 1    ⑤ Y axis lower side guide slide 2    ⑥ Y axis upper side guide slide 1
- ⑦ Y axis upper guide slide 2    ⑧ X axis right guide slide 1    ⑨ X axis right guide slide 2

Lubrication overview diagram 1

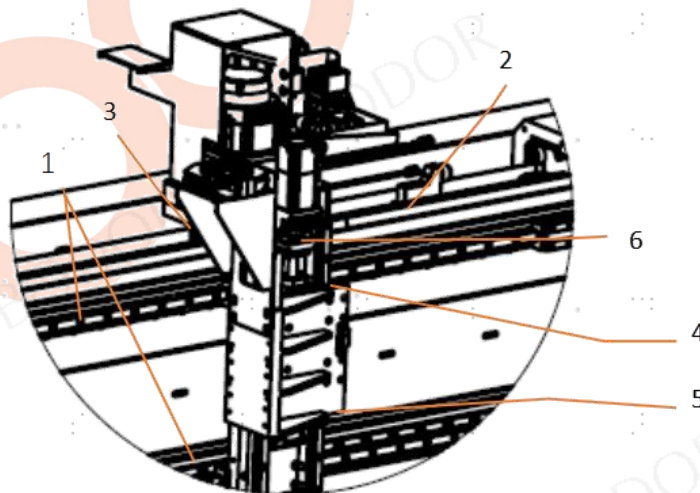

- ① X-axis left slider 1    ② X-axis left slider 2    ③ X-axis right slider 1    ④ X-axis right slider 2



- ⑤ Left rack of X-axis
- ⑥ Right rack of X-axis

Lubrication overview diagram 2

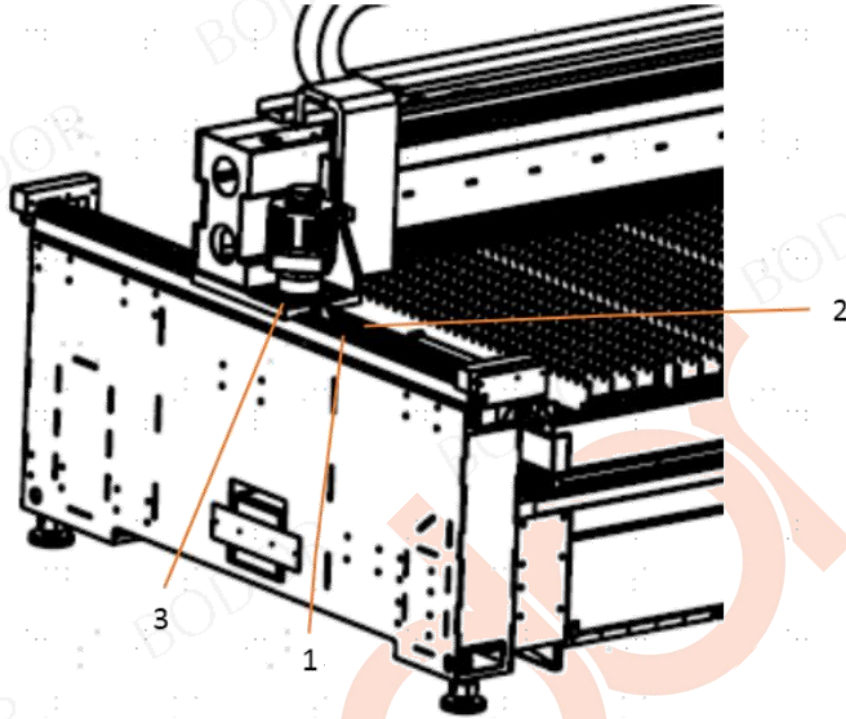

- ① X-axis rack
- ② X-axis guide rail
- ③ X-axis gear and rack meshing

Lubrication overview diagram 3

**Chart of Lubrication Overview**

Lubrication Part	Dosage	Recommended Lubricant	Logo	Viscosity and Consistency	Order No.
X-axis guide slide block	Configure by system	Guide oil for No.32 machine tool	Mobil	Kinematic viscosity 32	.....
Y-axis guide slide block	Configure by system	Guide oil for No.32 machine tool	Mobil	Kinematic viscosity 32	.....
Z-axis guide ball screw	100ml/time,500h/time	No. 1 Lithium Grease	Mobil	325 (Cone penetration)	.....



Z-axis guide slide block	Replace the rail oil box	Replace the rail oil box	_____	_____	.....
X,Y-axis gear rack	100ml/time,500h/time	00 lithium base grease	Mobil	415 (Cone penetration)	.....

**Tips:**

As for lubricants, we recommend using the listed lubricants or lubricants from other mineral oil companies with the same quality that can be proved.

**Maintenance Points 1**

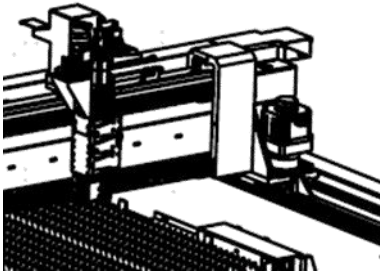

Job nature: Lubrication, Lubrication during the moving process on X, Y-axis guide rail.

Interval: Configure by system.

Tools/Materials: 32# guide oil.

Job description: Carry out a visual inspection of the quantity of lubricant on X, Y-axis guide rail; if you need to adjust it, please contact Bodor engineers.

**Maintenance Points 2**

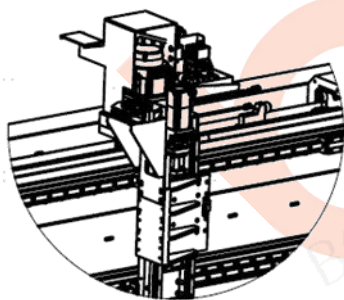

Job nature: Lubrication/Cleaning, Cleaning and lubrication of Z-axis guide rail and lead screw.

Interval: 500h/time.

Tools/Materials: Cleaning cloth, grease gun, No. 1 lithium grease, Guide oil for No.32 machine tool.

Job description: Remove the hood components; clean up the linear guide rail, slide block and ball screw with cleaning cloth; lubricate guide rail and ball screw, and add No. 1 lubricating grease to the guide slide block with a grease gun.



### Maintenance Points 3

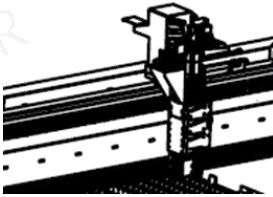
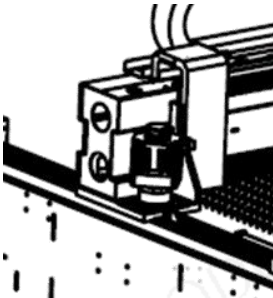

Job nature: Lubrication/Cleaning, Clean up X, Y-axis rack, gear and linear guide, and add lubricant to gear rack.

Interval: 500h/time.

Tools/Materials: Cleaning cloth, alcohol, brush, 00# Lithium grease.

Job description: Remove X-axis dustproof cover and Y-axis organ cover; clean up X, Y-axis rack, gear and linear guide rail with cleaning cloth; lubricate rack gear after cleaning.

### Maintenance Points 4



Job nature: Cleaning/Refueling/Oil change. Self-lubrication pump cleaning, refueling and oil changing

Interval: refueling once /100h, oil change once/1000h

Tools/Materials: Cleaning cloth, funnel, oil barrel; No. 32 guide oil

Job description: Check the oil storage capacity of the oil pump. If not, use 32# rail oil to replenish it; check that there is no abnormal wear on the lubrication pipelines.

### Maintenance Points 5

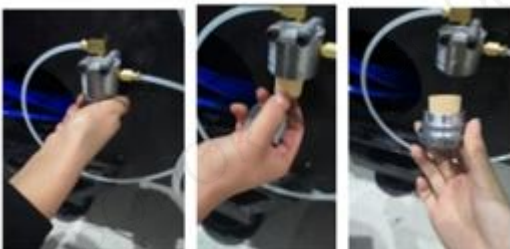

1

2

3

Job Nature : Clean , Regular cleaning of the filter element in the oil filter

Interval: 1000h/time.

Tools/Materials: cleaning cloth, air gun

Job Description: unscrew the filter base to remove the filter element, clean the filter element with an air gun, after which reinstall it and tighten the base.



## 1.3 Mechanical Part

### 1.3.1 Overview

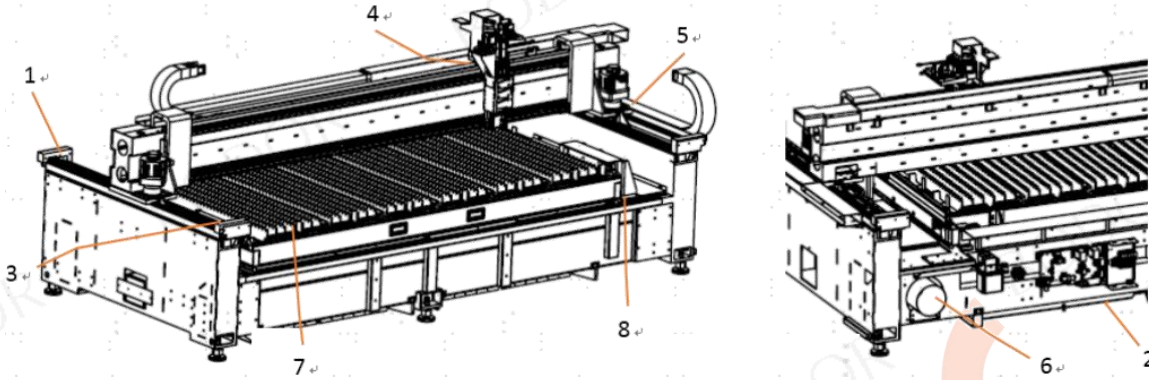

① X-direction dustproof cloth ② collection container -- waste car ③ X-axis protection plate

④ Y-axis rack and pinion engagement ⑤ X axis rack and pinion meshing ⑥ middle square tube

⑦ blade ⑧ mesa running track

### 1.3.2 Maintenance Instructions

#### Maintenance Points 1



Job Nature: Clean, Removal of slags and dust on the X, Y-axis dustproof cloth

Interval: 8h/time.

Tools/Materials: cleaning cloth, air gun

Job description: Regularly clean slags and dust on the dustproof cloth.





### Maintenance Points 2

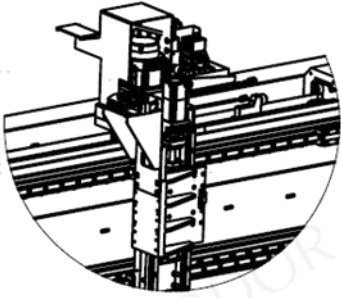

Job Nature: Clean

Interval: 40h/time.

Tools/Materials: cleaning cloth

Job description: Remove the head shell and clean up the internal dust and impurities.

### Maintenance Points 3

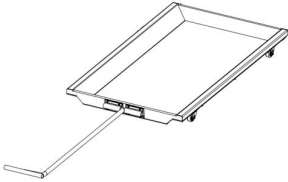

Job Nature: Clean up the slag and dust of the waste trolley.

Interval: 8h/time.

Tools/Materials: cleaning cloth, air gun

Job description: Regularly clean up the slag and dust on the waste trolley.

### Maintenance Points 4



Job Nature: Removal of slags and dust on the protection plate.

Interval: 8h/time.

Tools/Materials: cleaning cloth, air gun

Job description: Regularly clean the slag and dust on the X-direction anti-burning plate

### Maintenance Points 5

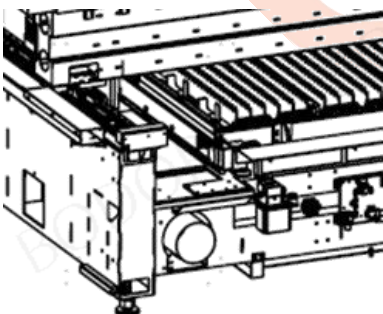

Job Nature: Clean the dust, slag, etc. of the exhaust duct.

Interval: 500h/time.

Tools/Materials: cleaning cloth, air gun

Job description: Periodically clean up the slag and dust of the exhaust pipe



### Maintenance Points 6

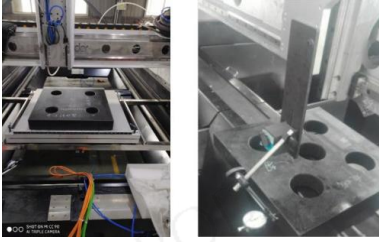

Job Nature: Precision maintenance of the equipment. Calibration of X, Y-axis verticality and X,Y-axis gear rack backlash

Interval: once/two and a half years

Interval: 5000h/time.

Tools/Materials: Dial indicator, micrometer, Fang Chi, internal and external hex wrench, cleaning cloth, Gear rack meshing backlash tooling.

Job description: disconnect the x-direction dust-proof cloth from the beam, remove the x-axis protection plate and the left and right guard plate of the cross beam to conduct vertical inspection on the X and Y axis. The tolerance of X and Y two-way marking is  $\leq 0.03\text{mm}/500\text{mm}$ , so as to ensure that the vertical of X and Y axis is  $\leq 0.03\text{mm}/500\text{mm}$ . Check the reverse clearance of x-axis gear rack engagement  $\leq 0.02\text{mm}$ .

Safety precautions: Pay attention to safety during operation!

### Maintenance Points 7



Job Nature: Inspection and cleaning of slag on the countertop blade.

Interval: 100h/time.

Tools/Materials: Sword grid cleaner (optional), electric hammer, iron hammer, etc.

Job description: Clean the blade regularly, choose electric hammer or iron hammer to clean the blade by vibration (pay attention to the table and personal safety) or choose our special sword grid cleaner. Can contact our customer service engineer for consultation.



### Maintenance Points 8

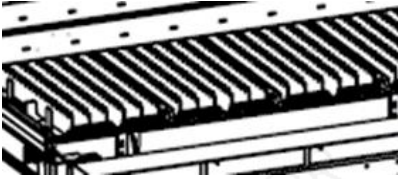

Job Nature: Blade slag cleaning

Interval: 100h/time.

Tools/Materials: Blade grating cleaner (optional), electric hammer, hammer, etc

Job description: Regularly clean the slag on the blade, choose electric hammer or hammer to vibrate the blade (pay attention to the table and personal safety) or choose our company's special blade grating cleaning machine. Please contact our customer service engineers for consultation.

### Maintenance Points 9



Nature of work: Clean appearance of equipment

Interval: 1 time/8h

Tools/materials: cleaning cloth, anhydrous ethanol, viscose remover, air pump

Work content: outside the equipment, easy to cause dirty ,easy to clean the

### Maintenance Points 10



Nature of work: equipment sheet metal

Interval: 1 time/40h

Tools/materials: cleaning cloth, anhydrous ethanol, viscose remover, air pump

Work content: the equiqment is easy to accumulate dust inside ,not easy to



## 1.4 Air Source Section

### 1.4.1 Overview

Oxygen and nitrogen pipeline module

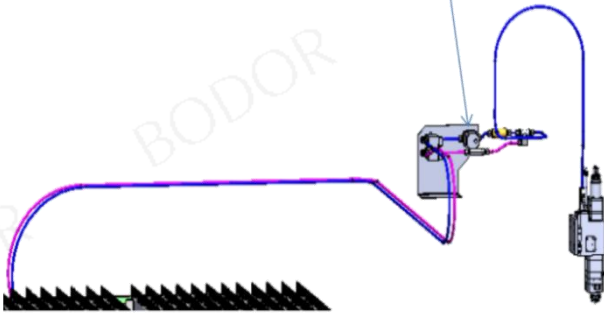

Sketch of the overview of the air source

Cutting gas circuit detection and filter module

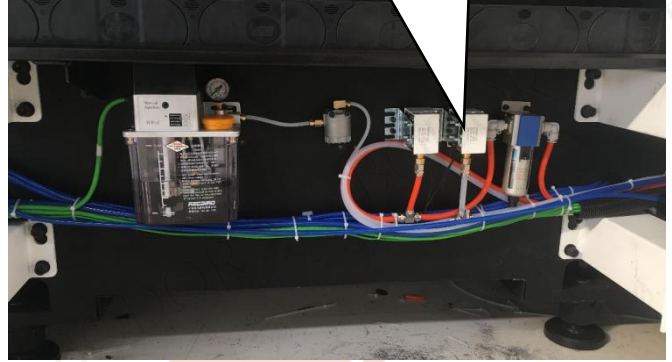

### 1.4.2 Maintenance Instructions

Maintenance of gas circuit elements and pipeline of the gas source section

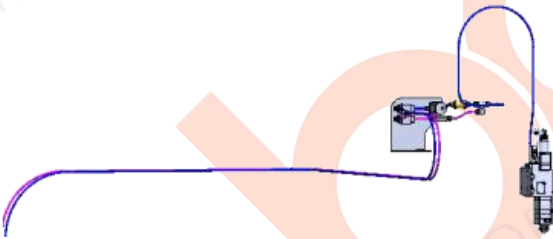

Job nature: Cleaning/Checking, Check gas source, gas circuit components, pipeline, etc.

Interval: once/week

Tools/Materials: Cleaning cloth, air gun, air pump.

Job description: Clean up the filter, pressure switch and nitrogen & oxygen pipeline module, observe air pressure stability of nitrogen gauge and oxygen gauge, and check whether there is air leakage in air duct.



Periodic replacement of filter elements in the filter

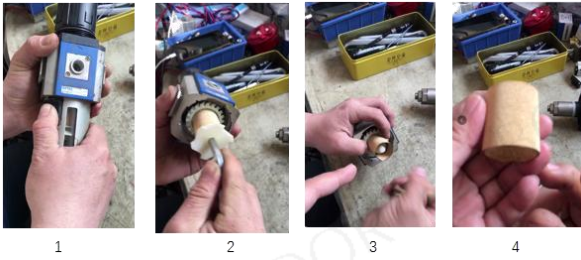

**Job Nature:** Replacement, Regular replacement of the filter element in the filter

**Interval:** once a year

**Tools/Materials:** cleaning cloth, inner hexagonal handle, filter element

**Job Description:** disassemble the filter to remove the filter element from the filter and replace it with a new one.

Clean and replace the filter element of the intake filtration device

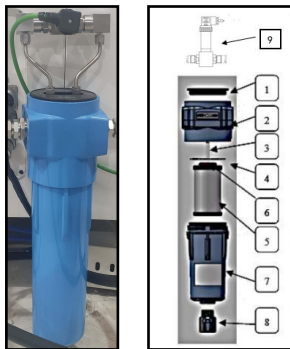

**Work item:** Clean and replace the filter element of the intake filtration device

**Interval:** 6000h

**Tools/materials:** filter element, air pump, cleaning cloth

**Work content:** Clean the surface of the intake filtration device with an air

## 1.5 Cooling Water Circulation Loop

### 1.5.1 Overview

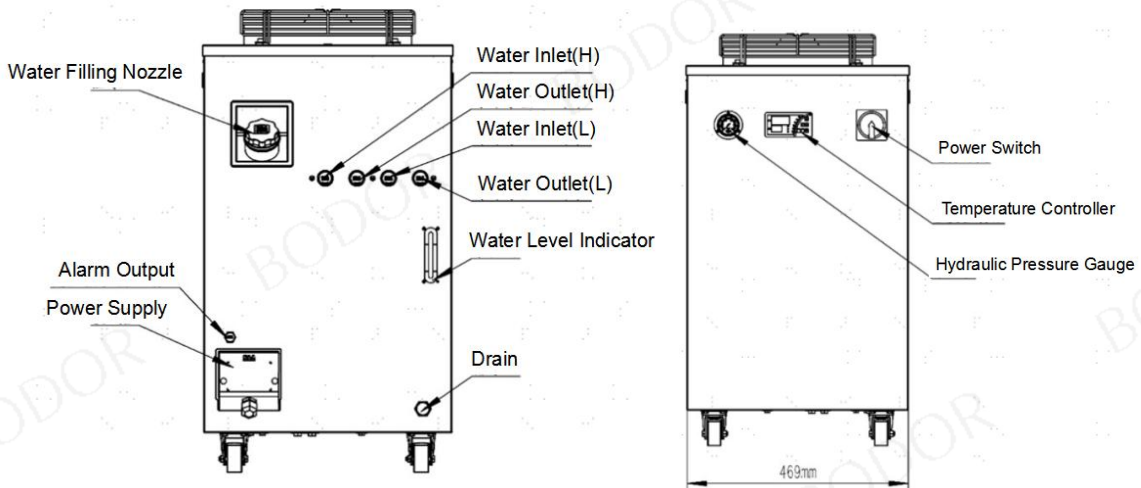

Overview of the cooling-water outline drawing

Water cooling machine detailed appearance diagram please see the specific brand manual, waterway circulation



schematic diagram please see the waterway schematic diagram in the random file according to the laser brand and power.

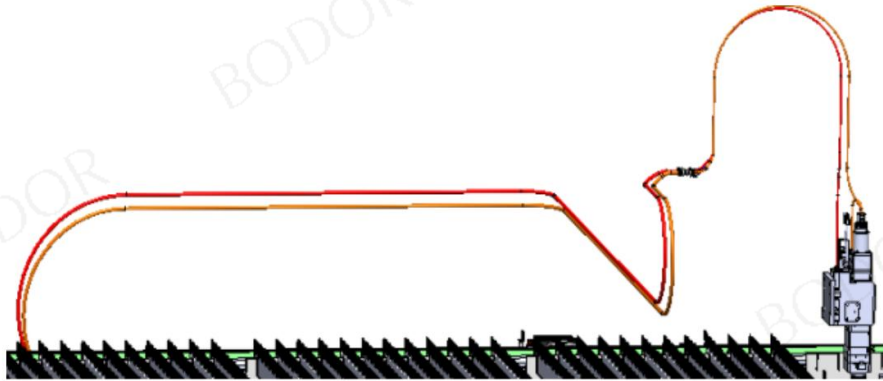

Sketch of the overview of the cooling-water circulation loop

## 1.5.2 Maintenance Instructions

### Maintenance Points 1

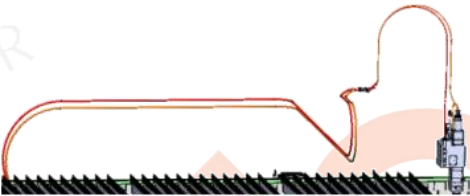

Job nature: Check. Check the circulating water loop pipeline, etc.

Interval: once/week

Tools/Materials: Observation.

Job description: Remove the motor cover blind, and open the head shell to check the overall circulating water route, and to make sure no water leakage in water pipe.

### Maintenance Points 2



Job nature: Cleaning and washing. Clean up the filter screen of the water-cooling machine (both sides)

Interval: once/quarter

Tools/Materials: Water pipe, cleaning tools, cleaning cloth

Job description: Press the filter screen “Jaw” of the water-cooling machine, remove the filter screen, and then clean up the filter screen with clean water.

**Maintenance Points 3**

Job nature: Replace cooling water.

Interval: once/every six months

Tools/Materials: Cleaning cloth, screwdriver, Ionized/distilled water

Job description: Remove the rear downside “Cover” of the water-cooling machine, open the “Water Outlet”, unscrew the “Filter”, completely discharge cooling water in the filter; completely discharge cooling water in the water-cooling machine inner, and then add cooling water in the “Water Inlet” according to water level displayed on the water gauge, note that cooling water must be deionized/distilled water specified by the laser manufacturer.

**Tip: Please follow the manufacturer's instructions for detailed introduction and operation of water cooler and laser.**



## 1.6 Maintenance of electrical parts and electrical cabinets

### 1.6.1 Overview

Electric cabinet layout:



- ① Exhaust fan and filter screen    ② Industrial computer    ③ Servo driver    ④ Terminal block
- ⑤ Miniature circuit breakers (MCB)    ⑥ Electronic transformer    ⑦ Relay    ⑧ Control card
- ⑨ Switching power supply    ⑩ Filter    ⑪ The inverter    ⑫ Braking resistor





### 1.6.2 Maintenance Guide

Maintenance Point	Frequency	Maintenance and Examination Contents
Routine Maintenance	Once every half month	<ol style="list-style-type: none"> <li>1) After power cut, clean the dust inside and outside the electric cabinet; then, both inlet and outlet air filters shall be checked, and replaced without delay if there is a fault;</li> <li>2) Components, wires and ends of the electric cabinet shall be checked for looseness or abnormal heating. Any fault, if any, must be handled without delay;</li> <li>3) Any components that are melted by electric shock with extreme high temperature of the coil, as well as ineffective action, oxidized protection device mechanism and worn off operating mechanism shall be replaced without delay;</li> <li>4) All kinds of sensors and meters shall be checked whether are installed and fixed for looseness. Any fault, if any, must be handled without delay;</li> <li>5) If there are abnormal hums in the operation of contactors, relays, solenoid valves and other induction components under normal voltage, relevant devices should be replaced without delay.</li> </ol>
Quarterly maintenance	Once every three months	<ol style="list-style-type: none"> <li>1) Daily maintenance contents are completed;</li> <li>2) Contactors, relays, switches, etc. shall be checked whether are in good contact with electric shock;</li> <li>3) The control circuits are tested whether they can work normally.</li> </ol>



Annual maintenance	Once a year	<ol style="list-style-type: none"> <li>1) Daily maintenance contents are completed;</li> <li>2) the nut of each power line connector is checked for looseness; it is required to further checked whether the wire insulation is damaged or aging, whether the connection point is in poor contact, and if necessary, disassemble and check the same, and even replace the power line;</li> <li>3) Dust and dirt in the wires, control components, sensors, electric control boxes, and meters shall be thoroughly removed; also, it is necessary to tighten the reinforcement bolts and terminal row crimping screws;</li> <li>4) Both inside and outside of all electric control boxes of the whole system of the equipment shall be cleaned, checking the wiring of contactor and controller, and whether there is any overload and heat on the wiring. Try to check the contact surface of the contactor for wear or ablation, and examine terminals, terminal box and each motor terminal box screws to ensure connection and insulation are tight and good;</li> <li>5) Check and calibrate each sensor and controller to ensure that they work without exceeding the standard range;</li> <li>6) Such control components as inverters, programmable controllers, and industrial computers must be cleaned and moisture-proof as per relevant maintenance requirements;</li> </ol>
--------------------	-------------	---

**Disclaimer: Any loss caused by improper use and maintenance shall be responsible by the customer!**

#### 1.7 Maintenance and maintenance of external auxiliary equipment

1) External power cables for the laser, water cooler, smoke purifier, air compressor and transformer, voltage regulator and main power box connected to the customer's power supply need to be tightened every three months to ensure that the terminals are securely connected, the insulation is good, and the normal operation of peripherals is guaranteed.

(Every three months, the customer is required to check whether the crimping screws and nuts of the power wire joints in the equipped power junction box are loose, whether the insulation of the wire is damaged or aging, and whether the connection points are in bad contact. Tighten the cables and replace the power wire and screws if necessary.)

2) For the operation and maintenance of each peripheral, such as laser, water cooler, air compressor and smoke purifier, please refer to the random manual of the supporting manufacturer for details:



《Laser Operation Manual》

《Water Cooling Machine Operation Manual》

《Operation Manual of Air Compressor》

《Smoke Purifier Operation Manual》 Etc.

Failure caused by failure to operate and maintain according to instructions is not covered by the warranty.



Change Human Life with Laser Technology

Jinan Shandong China  
Tel: +86-531-88690051  
Company website: [www.bodor.com](http://www.bodor.com)  
Jinan Bodor CNC Machine Co., Ltd.

